

SITI

SPA

SOCIETÀ ITALIANA TRASMISSIONI INDUSTRIALI



OT-MOT / PD-MPD / PL-MPL

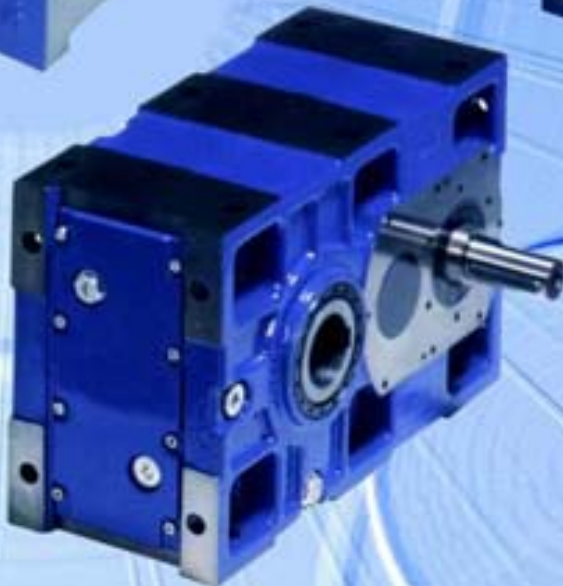

CATALOGO TECNICO - COMMERCIALE



TECHNICAL & COMMERCIAL CATALOGUE



TECHNISCHER HANDELSKATALOG

03.2005

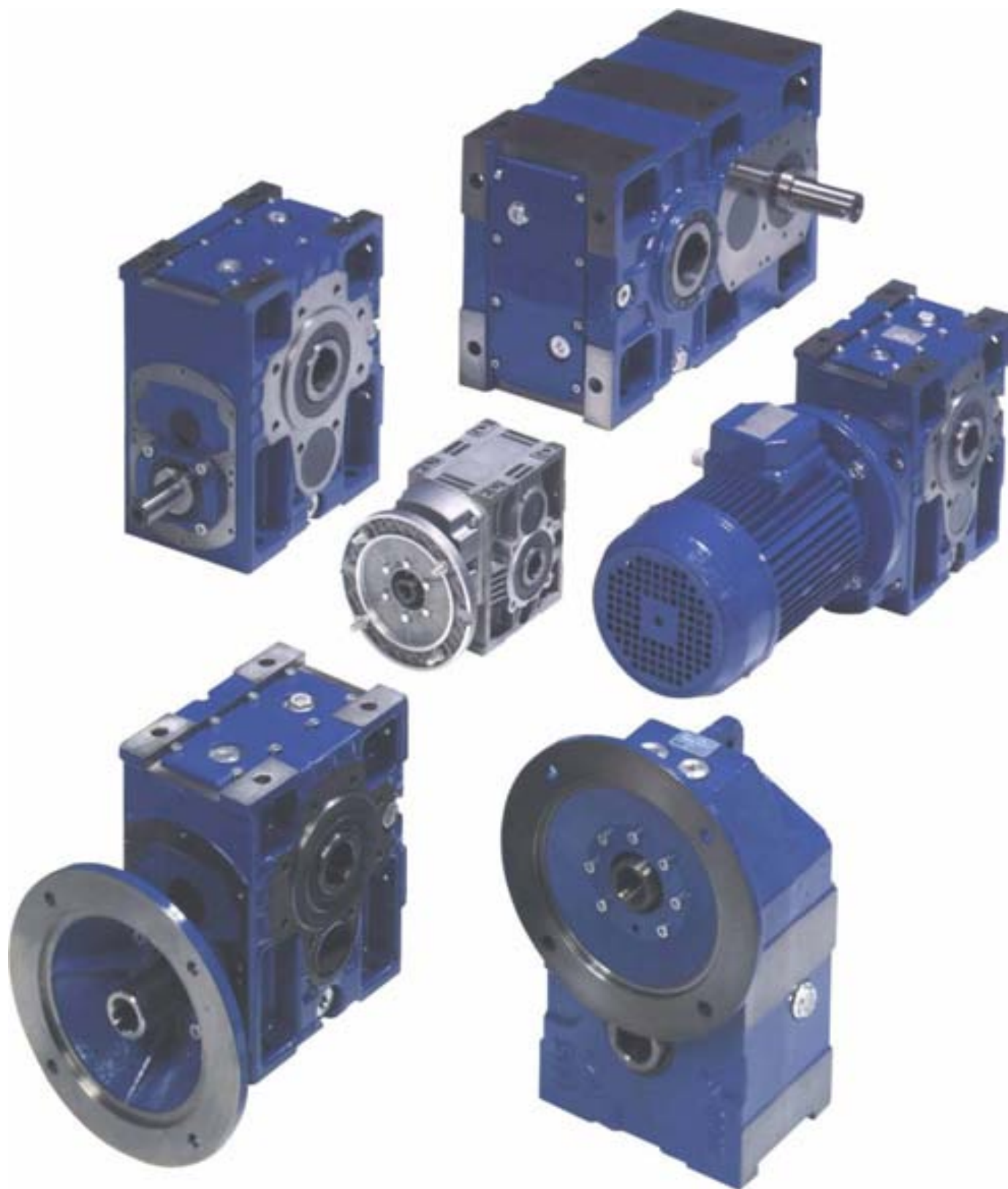

INDICE
LIST OF CONTENTS
 INHALTSVERZEICHNIS

	Pag. Page Seite
CARATTERISTICHE TECNICHE TECHNICAL FEATURES <i>TECHNISCHE BESCHREIBUNG</i>	3
PECULIARITA' COSTRUTTIVE CONSTRUCTION PECULIARITIES <i>KONSTRUKTIVE EIGENSCHAFTEN</i>	5
INSTALLAZIONE INSTALLATION <i>MONTAGEANLEITUNG</i>	6
MANUTENZIONE MAINTENANCE <i>WARTUNG</i>	8
STOCCAGGIO STOCKING <i>LAGERUNG</i>	9
LUBRIFICAZIONE LUBRICATION <i>SCHMIERUNG</i>	9
QUANTITA' DI LUBRIFICANTE LUBRICANT QUANTITY <i>ÖLMENGE</i>	11
POSIZIONI DI MONTAGGIO MOUNTING POSITIONS <i>EINBAULAGE</i>	11
DESIGNAZIONE CONFIGURATION <i>TYPENBEZEICHNUNG</i>	12
	./..

INDICE
LIST OF CONTENTS
INHALTSVERZEICHNIS

		Pag. Page <i>Seite</i>
	SENSO DI ROTAZIONE SENSE OF ROTATION <i>DREHRICHTUNG</i>	13
OT.. OT../3	PRESTAZIONI PERFORMANCES <i>LEISTUNG</i>	15
PL.. PL../3	PRESTAZIONI PERFORMANCES <i>LEISTUNG</i>	29
PD.. PD../3	PRESTAZIONI PERFORMANCES <i>LEISTUNG</i>	41
	ACCESSORI ACCESSORIES <i>ZUBEHÖR</i>	53

CARATTERISTICHE TECNICHE

- Riduttori dotati di rotismi a due o a tre stadi di riduzione:
- Sugli "OT":
I due stadi di riduzione sono formati da una coppia conica a dentatura spiroidale Gleason (dentature tipo Duplex) e da una coppia finale cilindrica con profilo ad evolvente, accuratamente corretto per una migliore resistenza ai carichi; i tre stadi di riduzione sono ottenuti aggiungendo un ulteriore stadio preliminare (precoppia) formata da due ingranaggi cilindrici con dentatura elicoidale, anch'essi accuratamente corretti per ottimale resistenza ai carichi.
- Sui riduttori PL e PD, sia la prima che la seconda riduzione sono realizzate con ingranaggi cilindrici a denti elicoidali con profili accuratamente corretti. Anche per questi riduttori, il terzo stadio di riduzione è ottenuto aggiungendo a monte (entrata riduttore) un ulteriore stadio di riduzione formato da due ingranaggi cilindrici con dentatura corretta.
- Sono realizzati in 5 grandezze: 63 – 80 – 100 – 125 – 160 (il numero che definisce la grandezza rappresenta l'interasse della riduzione finale seconda la serie di Renard R 10). Grandezza 56 disponibile solo per gli OT.
- Le coppie nominali trasmissibili sono comprese fra 100 Nm. e 4840 Nm.
- La capacità di carico delle dentature è stata verificata secondo le norme DIN 3990, UNI 8862, AGMA 2001 B 88 ed il progetto ISO 6336, con calcolo della resistenza sia al pitting che a flessione al piede del dente, per una durata nominale accuratamente bilanciata ed estremamente elevata.
- Gli alberi di ingresso, intermedio e di uscita sono tutti supportati da cuscinetti a rulli conici per una migliore regolazione del gioco e per maggiore resistenza ai carichi radiali e assiali.

TECHNICAL FEATURES

- **Gearboxes provides with trains of gears at 2 or 3 stages of reduction:**
- **On the "OT" range:**
The two stages of reduction consist of one bevel gear pair with spiral Gleason toothing (Duplex type) and one cylindrical final gear pair, with involute profile, accurately corrected in view of an improved strength; the three stages of reduction result from adding a further cylindrical helical gear pair, upstream of the other two stages, with accurately corrected involute profile in view of an excellent resistance to stresses.
- **On the PL and PD gearboxes, both the first and the second stage of reduction are accomplished with cylindrical helical gear pairs, with accurately corrected profiles.**
Even for these series of gearboxes, the third stage of reduction is obtained adding a further stage of reduction (primary reduction) provided with a cylindrical helical gear pair with corrected profile.
- **They are manufactured in 5 sizes: 63 – 80 – 100 – 125 – 160 (the number relevant to gearbox size means the center-to-center distance of the final reduction stage according to the Renard series R10). Size 56 available for OT only.**
- **The rated transmissible torques are included in the range from 100 Nm. to 4840 Nm.**
- **Load capacities of toothing comply with DIN 3990, UNI 8862, AGMA 2001 B88 norms and the ISO 6336 draft proposal, both with the surface pitting resistance and the tooth root bending strength calculation, in view of an accurately balances and extremely high nominal life.**
- **Input shafts, output shafts and intermediate shafts are all supported by taper roller bearings, in view of an improved adjustment of backlash and high strength to radial and axial loads.**

TECHNISCHE BESCHREIBUNG

- *Für diese Getriebe sind zwei oder drei Untersetzungsstufen vorgesehen:*
- *Auf „OT“ Baureihe:*
Die zwei Getriebestufen werden durch eine Gleason-spiralverzahnte kegelradpaarung (Typ Duplex) und eine evolvent-schrägverzahnte Zahnradpaarung erreicht.
Um eine gute Belastungsübertragung zu erzielen, werden diese sehr sorgsam hergestellt.
Die drei Getriebestufen werden durch eine vorgeschaltete Zahnradstufe (Vorstufe) erreicht, die gleichen Eigenschaften der zweiten Untersetzungsstufe besitzt.
- *Auf PL und PD, die zwei Getriebestufe werden durch zwei evolvent-schragverzahnte Zahnradpaarungen erreicht. Die drei Getriebestufen werden durch eine vorgeschaltete Zahnradstufe (evolvent-schragverzahnte Zahnradpaar, die Vorstufe) erreicht.*
- *Die neuen Getriebe werden in fünf Größen gefertigt:*
63 – 80 – 100 – 125 – 160 (Die Größe ist nach dem Achsabstand der Abtriebsstufe definiert; Renard R10).
Größe 56 verfügbar nur für OT.
- *Die Abtriebsdrehmomente reichen von 100 bis 4840 Nm.*
- *Die spezifische Zahnbelastung ist nach DIN 3990, UNI 8862, AGMA 2001 B88 und dem Entwurf ISO 6336 festgelegt und dient der Berechnung der Festigkeit in Bezug auf Pitting und Biegefestigkeit im Zahngrund für eine ausgewogene, normal lange Lebensdauer.*
- *Für eine bessere Axialspieleinstellung und für höhere radiale und axiale Belastungen sind die Wellen im Eingang und beide die Abtriebsstufe und die Vorstufe mit Kegelrollenlagern gelagert.*

- Tutti gli ingranaggi sono costruiti in acciaio da cementazione (20 Mn Cr 5 o materiali di equivalente resistenza e temprabilità), e sottoposti a cementazione, tempra e distensione per elevata resistenza alle sollecitazioni statiche e dinamiche e all'usura.
- Gli alberi lenti cavi (soluzione standard) sono costruiti in ghisa sferoidale GS-400.
- Gli alberi lenti pieni, semplici o doppi (soluzione optional) sono costruiti in acciaio da bonifica 42 Cr Mo 4, o materiali di simili proprietà.
- Le carcasse sono costruite in ghisa G 25 secondo UNI 5007, salvo OT 56 in alluminio pressofuso.
- Tutti i nuovi riduttori offrono la possibilità di accettare elevati carichi esterni, sia radiali che assiali, comunque orientati: le nostre tabelle forniscono i valori applicabili senza problemi in tutte le condizioni, per casi speciali sarà comunque possibile valutare l'eventuale idoneità con calcolo specifico.
- I rendimenti dinamici sono molto elevati; 0.96 nelle versioni a due stadi e 0.92 nelle versioni a tre stadi.
- E' possibile operare in condizioni di esercizio particolarmente severe garantendo ancora delle durate soddisfacenti; a questo proposito, raccomandiamo di riferirsi scrupolosamente alle indicazioni dei nostri cataloghi tecnici e, nei casi dubbi, riteniamo indispensabile interpellare il nostro servizio tecnico.
- **All gears are made in case-hardening steel (20 Mn Cr 5 or materials of equivalent strength and hardenability) and are submitted to case-hardening, quenching and stress-relieving, to give high resistance to static and dynamic stresses and to wear.**
- **Hollow output shafts (standard solution) are manufactured in nodular cast iron GS-400.**
- **The solid output shafts, with single or double extension (optional solution) are made in hardening and tempering steel 42 Cr Mo 4, or materials of similar properties.**
- **Housings are made in cast iron G 25 according to UNI 5007 specification, except OT 56 in aluminium pressure die casting.**
- **All the new gearboxes offer a chance to accept high external loads, both radial and axial ones, wherever oriented: our tables give the ratings which can be applied with no troubles in any condition, for special application purposes it is however advisable to evaluate the possible suitability through a specific calculation.**
- **Dynamic efficiencies are very high: 0.96 in the two stage reduction versions and 0.92 in the three stage reduction versions.**
- **It is allowed to operate in particularly severe conditions of application, still saving sufficiently satisfactory life times; in connection with this, we recommend to strictly adhere to the indications of our technical catalogue and, if in doubt, to contact our technical dept.**
- *Alle Zahnräder sind aus Einsatzstahl gefertigt (20 Mn Cr 5 oder in Bezug auf Härte und Festigkeit ähnliche Werkstoffe). Um eine höhere Verschleißfestigkeit sowie höhere statische und dynamische Beanspruchungen zu ermöglichen, werden die Zahnräder einsatzgehärtet und spannungsfrei gegläht.*
- *Die Abtriebshohlwellen werden in der Standardausführung aus Sferoguß GS-400 gefertigt.*
- *Die auf Wunsch lieferbaren, einseitigen und zweiseitigen Abtriebsvollwellen sind aus Stahl 42 Cr Mo 4 oder aus einem vergleichbaren Werkstoff hergestellt.*
- *Das Gehäuse wird aus G 25 (Guss) nach UNI 5007 gefertigt, mit der Ausnahme von OT 56 in Alu-Druckguß.*
- *Alle neue Getriebe haben den Vorteil, daß höhere radiale und axiale Belastungen übertragen werden können. Bei den in unseren Tabellen angegebenen Daten handelt sich um Standardangaben für allgemeine Anwendungen in sonderfällen können auf Wunsch projektspezifische Berechnungen durchgeführt werden.*
- *Der dynamische Wirkungsgrad dieser Getriebe ist sehr hoch: 0,96 bei den zweistufigen und 0,92 bei den dreistufigen Getrieben.*
- *Es ist möglich diese neue Getriebe auch bei anspruchsvollen Einsatzfällen zu verwenden und eine befriedigende Lebensdauer zu erzielen. Deshalb ist es ratsam, nach den Katalogangaben zu richten und bei auftretenden Unsicherheiten mit unserem technischen Büro Rücksprache zu nehmen.*

PECULIARITA' COSTRUTTIVE

- Elevata compattezza ed estrema versatilità di impiego
- Modularità costruttiva, che consente agevoli modifiche della posizione di installazione e montaggio
- Carcassa principale monoblocco ed ulteriore carcassa per ospitare lo stadio di riduzione addizionale (precoppia), facilmente installabile e collegabile alla carcassa principale, utilizzata anche per le versioni PAM a due stadi
- Struttura robusta e resistente, in grado di accettare motori di notevole grandezza e di trasmettere momenti torcenti, sia nominali che di spunto, molto elevati
- Impiego di motori normalizzati, calettati direttamente sull'estremità cava dell'albero veloce
- Elevata capacità di olio per una lubrificazione ottimale
- Elevate capacità di scambio termico, con possibilità di operare anche in condizioni di servizio particolarmente gravose
- Valori contenuti di rumorosità e ridotte possibilità di innesco di vibrazioni in virtù del tipo di costruzione e di montaggio modulare, che minimizza il rischio di montaggio mal eseguito e di allineamenti scorretti
- Livello di qualità più affidabile e ripetitivo del prodotto assemblato
- Ridotte necessità di manutenzione

CONSTRUCTION PECULIARITIES

- **High compactness and extreme versatility of usage**
- **Modular construction, enabling easy changes in the installation and assembling positions**
- **Main monobloc housing and a further housing used for locating the additional reduction stage (primary reduction stage), which can be easily installed and connected to the main housing, used even in the two stages versions equipped with PAM (motor pre-arrangement)**
- **Strong and highly resistant structure, suitable to fit even particularly powerful motors and to transmit remarkable torques, both rated and starting ones**
- **Use of standardised motors, directly coupled on to the hollow end of the input shaft**
- **High oil capacity, in view of a highly efficient lubrication**
- **High thermal exchange capacity, with chances to operate even in heavy duty conditions of application.**
- **Considerably low sound levels and minimized vibration risks thank to the modular construction which prevents from the risk of wrong assembling and uncorrect alignments**
- **More reliable and repeatable level of quality of the assembly**
- **Reduced needs of maintenance**

KONSTRUKTIVE EIGENSCHAFTEN

- *Kompakte Einheit und hohe Vielseitigkeit in der Anwendung*
- *Einheitliche Bauform, so daß die Montage in allen Einbaulagen problemlos erfolgen kann*
- *Das Hauptgehäuse (Monoblock) ist gleichzeitig für den Anbau einer Vorstufe für höhere Untersetzungen vorgesehen, die auch in der Version für Motoranbau (PAM) leicht zu montieren ist*
- *Eine robuste Konzeption und Bauweise erlaubt den Anbau größerer Motoren, um höhere Anlauf - bzw. Nennmomente zu übertragen*
- *Verwendung von Normmotoren die direkt mit der Eingangshohlwelle gekoppelt werden*
- *Ausreichender Innenraum im Gehäuse erlaubt den Einsatz der Getriebe auch in extremen Einsatzfällen*
- *Bedingt durch die Modul-Bauweise und Montage werden Geräusche und Vibration sowie Montagefehler vermindert*
- *Gleichbleibend hohe Qualität des fertigen Produkts*
- *Geringer Bedarf an Wartung*

INSTALLAZIONE

Nell'installazione dei riduttori, occorre attenersi ad alcune regole e norme di comportamento molto rigorose:

1 - Occorre sistemare il motoriduttore in modo che sia consentito un ampio passaggio di aria per la refrigerazione del riduttore e del relativo motore, soprattutto vicino alla ventola di refrigerazione.

2 - Si devono evitare, o almeno ridurre al minimo, le strozzature nei passaggi dell'aria e soprattutto la presenza di fonti di calore site nelle vicinanze del riduttore e tali da poter influenzare sensibilmente la temperatura dell'aria di refrigerazione.

3 - Si deve inoltre evitare che la circolazione dell'aria sia insufficiente, il che potrebbe compromettere il regolare smaltimento del calore. Si noti infatti che a regime il riduttore produce una potenza termica in costante equilibrio con la potenza termica che può essere smaltita: pertanto, una riduzione della possibilità di smaltimento del calore porta ad un incremento della potenza termica dissipata all'interno del riduttore, e quindi ad un incremento della temperatura del medesimo.

4 - Nell'impiego di motori asincroni trifase, quando il loro avviamento è a vuoto o comunque sotto carichi molto ridotti, è necessario realizzare degli avviamenti molto dolci, correnti di spunto molto contenute, sollecitazioni anch'esse contenute, e se necessario adottare l'avviamento stella/triangolo.

5 - E' essenziale montare il motoriduttore in modo che non subisca vibrazioni in opera. Infatti la vibrazioni, oltre a causare rumorosità, determinano altri problemi come il possibile progressivo svitamento delle viti di collegamento, ed un incremento dei carichi degli organi interni soggettati a fenomeni di fatica.

6 - Le superfici di fissaggio devono essere pulite e di rugosità sufficiente onde far sì che si abbia un buon coefficiente di attrito. In presenza di carichi esterni, è suggeribile impiegare spine e arresti positivi. Nelle viti e nei piani di unione è indispensabile utilizzare degli adesivi autobloccanti.

7 - Qualora l'applicazione implichi dei sovraccarichi di lunga durata, frequenti urti e pericoli di bloccaggio, è assolutamente suggeribile installare dei salvamotori, dei limitatori elettronici di coppia, giunti idraulici, giunti di sicurezza, o unità di controllo.

INSTALLATION

In the installation of gearboxes, please adhere to the following instructions:

1 - The gearbox must be positioned in a way as to allow a free passage of the air for cooling both the gearbox and the relative motor, especially close to the motor cooling fan.

2 - Avoid as much as possible any obstruction to the air flow and especially heat sources very near to the gearbox, which might affect the temperature of the cooling air.

3 - It must be avoided insufficient air recycle, which could hinder a steady heat dissipation. It should be noted that, in normal running conditions, the gearbox develops a thermal power in a constant balance with the one which can be dissipated. Therefore, if heat dissipation chances sink down, an increase of the thermal power dissipated inside the gearbox occurs, thus a temperature increase of the same.

4 - In the use of asynchronous 3-phase motors, when startings at no load or anyway with very small load occur, there is necessity to accomplish smooth starts. low starting currents and limited stresses, therefore star-delta starting are recommended.

5 - It is essential to mount the gearbox so as not to receive vibrations while working. In fact vibrations, besides causing noise, give rise to several other potential problems, like progressive connection bolts unscrewing and an increase of fatigue stresses on the internal parts.

6 - Before mounting, clean thoroughly all mating surfaces. They must be sufficiently rough to accomplish a good friction coefficient. Whenever there are outer loads, it is recommended to use pins and positive stops. Self-locking adhesives should be used on the bolts and joining surfaces of the machine frame to prevent gearbox and driven machine to get loose.

7 - If the application involves overloads of long periods of time, heavy shocks or a danger of jamming, it is strongly suggested to fit motor protections, electronic torque limiters, hydraulic couplings, safety couplings, control units or similar devices.

MONTAGEANLEITUNG

Für einen korrekten Einbau der Getriebe ist es wichtig, daß bestimmte Regeln streng eingehalten werden:

1 - Bei der Aufstellung des Getriebemotors muß gewährleistet sein, daß zwecks Kühlung des Motors und des Getriebes insbesondere in Nähe der Motorlüfterhaube genügend Umluft vorhanden ist.

2 - Sämtliche Umstände, die die Luftzirkulation behindern können, sollten beseitigt oder weitestgehend verringert werden. Dies gilt ebenfalls für Wärmequellen, die die Kühlung des Getriebes bzw. des Getriebemotors beeinflussen können.

3 - Eine ausreichende Luftzirkulation sollte unbedingt angestrebt werden, da sonst die Wärmeabfuhr behindert werden kann. Es ist anzumerken, daß das Getriebe im vollen Beharrungszustand eine thermische Leistung erzeugt, die durch eine ausreichende Belüftung abgeführt werden kann. Erfolgt dieser Vorgang nicht oder nur teilweise, so vergrößert sich die aufgebrauchte thermische Leistung im Getriebe und es erfolgt eine unerwünschte Wärmezunahme.

4 - Bei Verwendung von Dreiphasen-Drehstrommotoren, bei denen der Anlauf ohne Belastung oder mit geringer Last erfolgt, ist ein sanfter Anlauf erforderlich. Dieser kann durch eine geringe Stromzufuhr im Anlauf oder durch eine Stern-Dreieck-Schaltung bewirkt werden.

5 - Es ist von großer Bedeutung die Getriebe so zu montieren, daß während des Betriebs keine Vibrationen erzeugt werden. Vibrationen erzeugen Geräusche und tragen mit der Zeit dazu bei, daß sich die Befestigungs- und Verbindungsschrauben lockern. Zusätzlich erfolgt eine Zunahme der inneren Belastung und somit eine Ermüdung der Maschinenteile.

6 - Die Aufstellungsfläche muß so bearbeitet sein, daß eine Oberflächenhaftung erfolgen kann. Bei extrem hohen Belastungen empfiehlt es sich, Stifte oder Feststellvorrichtungen zu verwenden. Für Schrauben und Aufstellungsflächen ist die Verwendung von Haftmaterialien unentbehrlich.

7 - Treten in der Anlage über einen längeren Zeitraum höhere Belastungen oder stoßartige Abläufe auf oder besteht eine Blockierungsgefahr, so ist der Einsatz von Motorschutz, elektrischen Drehmomentschutzeinrichtungen, Hydraulik-Kupplungen, Sicherheitskupplungen oder Überwachungsgeräten unbedingt angeraten.

8 - Per servizi con elevato numero di avviamenti a carico, è consigliata la protezione del motore con sonde termiche, onde evitare che si raggiungano pericolose condizioni di sovraccarico del motore stesso, che potrebbero portare gli avvolgimenti a surriscaldare e quindi a fondere.

9 - Riveste una importanza fondamentale agli effetti della buona resa in condizioni operative che venga curato al massimo l'allineamento del riduttore rispetto al motore e alla macchina che deve essere comandata.
Tutte le volte in cui ciò è possibile, vale la pena di installare dei giunti elastici. Si consiglia di procedere con molta precisione in tutti quei casi in cui viene montato un supporto esterno, perchè eventuali errori di disallineamento di quest'ultimo si ripercuoterebbero in sovraccarichi con conseguente distruzione di un cuscinetto o dell'albero.

10 - All'atto della messa in opera, ci si deve sempre accertare che sia consentito lo scarico dell'olio dal foro di scarico e che il tappo di livello sia accessibile agevolmente alla vista per controlli periodici.

11 - Prima di procedere al montaggio, ci si dovrà curare di pulire bene e lubrificare le superfici a contatto, al fine di evitare pericolo di ossidazioni e di grippaggi.

12 - Gli organi che vengono calettati all'albero cavo del riduttore (in tolleranza H7) devono essere eseguiti con perni lavorati in tolleranza h6.
Dove il tipo di applicazione lo richieda, si può prevedere un accoppiamento con leggera interferenza (H7-j6).

13 - Nei limiti del possibile, è consigliato di evitare il montaggio dei pignoni a sbalzo, e di contenere al minimo indispensabile la tensione di cinghie e di catene.

14 - Prima della messa in funzione della macchina, accertarsi che la posizione del livello del lubrificante sia conforme alla posizione del riduttore e che sia stato usato il lubrificante consigliato.

15 - Durante la verniciatura, si consiglia di proteggere il bordo esterno dagli anelli di tenuta, per evitare che la vernice ne essichi la gomma, pregiudicando la tenuta.

16 - Non usare mai il martello per il montaggio e lo smontaggio degli organi calettati, ma utilizzare i fori maschiati previsti in testa agli alberi dei riduttori.

8 - When duty cycle involves high frequency of starts on load, it is recommended to provide a motor protection with thermal gauges, in order to avoid that dangerous overloading conditions of the motor are achieved, which could cause motor windings to overheat and then to melt.

**9 - It is essential, in view of a satisfactory gearbox performance, to care that the gearbox is correctly aligned with the motor and the driven machine.
Whenever possible, flexible couplings should be interposed.
It is needed to proceed carefully whenever an outboard bearing is used, considering that any possible misalignment of this piece would cause tremendously high overloads, with a subsequent failure of a bearing or the shaft.**

10 - At the time of gearbox installation, it must be ensured that oil can be removed through the discharge plug and that the level indicator is easily accessible at the human eye for periodical inspections.

11 - Prior to assembly, ensure to clean well and to lubricate mating surfaces, in order to prevent any risk of oxidation and seizure.

**12 - Parts which are fitted with the gearbox hollow shaft (tolerance H7) must be carried out with shafts machined with tolerance h6.
When required by the application, a fitting with low interference (H7-j6) might be provided.**

13 - It is recommended to avoid to fit cantilever mounted pinions, and to hold the pre-loading of belts and chains to the minimum possible value.

14 - Prior to machine start up, make sure that oil level is suitable for the gearbox assembling position and that the recommended oil type has been used.

15 - At the time of painting, it is advisable to protect the outer board of seals, in order to avoid that paint makes rubber dry, thus affecting the sealing effect.

16 - Never use the hammer for mounting/dismantling of the keyed parts, but use the tapped holes provided on the head of the gearbox shafts.

8 - Bei mehreren hohen Anläufen pro Stunde unter Belastung empfiehlt es sich, den Motor mit Thermoschutz zu versehen. Dieser schützt den Motor vor überhöhten Belastungen und hohen Temperaturen. Damit wird ein Durchbrennen der Wicklung verhindert.

9 - Um einen ruhigen Lauf und eine hohe Lebensdauer des Getriebes zu ermöglichen, ist es entscheidend, daß die zu verbindenden Wellen fluchten. In allen Fällen, bei denen es die Möglichkeiten erlauben, lohnt sich die Verwendung elastischer Kupplungen. Werden zusätzliche Lagerböcke oder Stützen benötigt, so müssen diese mit großer Genauigkeit montiert werden. Eventuelle Fluchtungsfehler erzeugen höhere Belastungen und zerstören die Lagerung der Wellen.

10 - Bei der Montage sollte man sich vergewissern, daß das Öl problemlos durch die Ölablaßschraube abgelassen werden kann und das Ölstandsaug für periodische Ölstandsüberprüfungen zugänglich ist.

11 - Vor der Montage müssen alle Berührungsflächen gut gesäubert und durch geeignetes Oxidierungsmittel geschützt werden.

*12 - Wellen, die in die Getriebehohlwellen (Toleranz H7) aufgezogen werden, müssen mit der Toleranz h6 gefertigt werden.
In Anwendungsfällen, bei denen eine Toleranz mit leichtem Übermaß erforderlich ist, empfehlen wir H7-j6.*

13 - Grundsätzlich sollte die freifliegende Montage von Kettenrädern, Zahnradern, Zahnriemenrädern und Trommeln auf die Welle vermieden werden. Auch die Riemen- bzw. die Kettenspannung sollte auf ein Minimum beschränkt werden.

14 - Vor Inbetriebnahme vergewissern Sie sich bitte, daß der Ölstand und die vorgeschriebene Ölart eingehalten werden.

15 - Um eine Verhärtung der Dichtlippen und eventuelle spätere Undichtigkeiten zu vermeiden, empfiehlt es sich die Wellen dichtung bei Lackierarbeiten zu schützen.

16 - Für Montage oder Demontage von Antriebs-elementen auf die Welle sollte niemals ein Hammer zu Hilfe genommen werden. Benützen Sie für diese Tätigkeiten bitte die stirnseitigen Gewinde an der Welle.

MANUTENZIONE

1 - Controlli da eseguire di routine.
In generale, è necessario controllare periodicamente la pulizia delle superfici esterne e dei passaggi di aria per la ventilazione.
Ci si dovrà accertare con buona frequenza temporale che non si verifichino perdite di lubrificante attraverso le guarnizioni di tenuta, le flange di attacco e di collegamento, le viti di fissaggio dei coperchi, i cappellotti ecc..

2 - Costante controllo che il lubrificante sia al livello corretto.
Suggeriamo di controllare abbastanza spesso, quando il riduttore sia fermo e sia sufficientemente raffreddato, che il livello dell'olio si sia mantenuto corretto.
Servirsi a tal fine del tappo di livello, che dovrà pertanto essere mantenuto pulito e trasparente.
Qualora si constati attraverso il tappo stesso che potrebbe essere presente un deposito interno di sporco, conviene accertarsi che non sia penetrato entro alla carcassa del materiale estraneo, quale polvere, sabbia, acqua.
Qualora il livello dell'olio si sia abbassato al di sotto del livello prescritto, si deve provvedere immediatamente al rabbocco.
I danni cui il riduttore può andare soggetto qualora operi con scarso lubrificante sono estremamente gravi e rapidi, spesso irreparabili.
Il livello scarso del lubrificante interno compromette le condizioni di scambio termico e, a causa del ridotto potere refrigerante e di asportazione del calore, determina un incremento della temperatura operativa interna, soprattutto nel contatto fra i fianchi dei denti.

3 - Accertamento della temperatura operativa.
Possibilmente, ci si dovrebbe servire di idonei strumenti per accertare la temperatura esterna della carcassa.
Siccome in condizioni di impiego ottimali, si vengono comunque a verificare dei salti di temperatura di almeno 15-20°C rispetto all'esterno, le temperature raggiunte normalmente dalla carcassa potrebbero non essere sopportabili dalla pelle umana.
Pertanto, ritenere che un riduttore scaldi troppo solo perché non si riesce a tenervi una mano sopra è una affermazione destituita di ogni fondamento (infatti, appena sopra i 50°C non si riesce più a tenere una mano sopra alla carcassa del riduttore).
E' importante accertare che la temperatura operativa alla quale il riduttore si stabilizza a regime, a parità di condizioni di impiego, sia più o meno costante: sintomo, questo, che il riduttore sta operando senza che stiano insorgendo fenomeni negativi.

MAINTENANCE

1 - Routinary checks.
It is necessary to periodically check that outer surfaces and the passages for the air for cooling are clean.
It must be frequently ensured that oil does not leak through seals, connection flanges, attaching hardware of covers, cups etc..

2 - Constant checks that oil is at the proper level.
We recommend to check often, when the gearbox is stopped and sufficiently cool that oil has kept at the correct value.
For doing this, sight glasses must be used, which therefore must be kept clean and transparent.
Whenever it is ensured, as a result of the visual inspection through the sight glasses, that there is an internal deposit of dirt, it is convenient to verify if foreign material, like dust, sand, water has come into the housing.
If oil level has sunk down, below the prescribed level, it must be provided immediately to fill it up.
When operating with poor quantity of oil, the gearbox could suffer serious and fast damages.

3 - Measurement of the operating temperature.
Possibly, suitable means should be used for determining the outside temperature of the housing.
Since, in normal conditions of use, an internal temperature rise of at least 15-20°C occurs compared with outside temperature, it would be wrong to state that a gearbox is too hot simply because it cannot be touched with the naked hand.
It is important to ensure that the operating temperature reached by the gearbox in a steady stage and at similar conditions of use is nearly the same: this allows to assume that gearbox operates correctly and no potentially degenerative events are going to occur.

WARTUNG

1 - Auszuführende Routinekontrollen.
In gewissen Zeitabschnitten ist es grundsätzlich erforderlich Kontrollen am Getriebe durchzuführen. Diese müssen zunächst äußerlich sauber gehalten werden. Auch der Luftdurchgang, der für die Kühlung verantwortlich ist, muß regelmäßig gereinigt werden.
Weiterhin sollte man sich vergewissern, daß kein Schmiermittelverlust an Wellendichtring, Abdichtungsdeckel, Befestigungs- bzw. Verbindungsflansch und Deckelschraube aufgetreten ist.

2 - Konstante Überprüfungen des Ölstandes.
Wir empfehlen diese Kontrollen beim Stillstand und in kaltem Zustand des Getriebes durchzuführen.
Das Ölstandsauge muß stets sauber und klar gehalten werden.
Werden durch die Ölablaßschraube im Getriebeinnern Ablagerungen festgestellt, so ist unbedingt zu prüfen, ob Wasser, Sand oder Staub in das Getriebe eingedrungen sind.
Ist der Ölstand niedriger als vorgeschrieben, so muß er nachgefüllt werden.
Die Schäden, die durch fehlende Schmierung auftreten können, treten schnell auf, sind oft schwer und häufig irreparabel.
Fehlendes Schmiermittel beeinflusst den Wärmeaustausch im Getriebe und bewirkt eine Wärmezunahme, insbesondere zwischen den Zahnflanken.

3 - Feststellung der Betriebstemperatur.
Mit geeigneten Meßgeräten kann die Betriebstemperatur am Gehäuse gemessen werden. Im optimalen Betriebszustand kann zwischen innerer und äußerer Temperatur ein Unterschied von 15° - 20°C festgestellt werden, so daß eine Berührung der Gehäuseoberfläche eventuell nicht mehr möglich ist. Deshalb zu behaupten, daß das Getriebe zu heiß wird, weil man die Hand nicht auf das Gehäuse halten kann, wäre falsch und unbegründet. (Bereits bei 50°C reagiert der menschliche Körper empfindlich und empfindet Schmerz.)
Es ist sehr wichtig sich zu vergewissern, ob sich die Getriebetemperatur in ihrem Bereich stabilisiert. Dies bedeutet, daß das Getriebe seinen normalen Arbeitsbereich erreicht hat.

4 – Pulizia

La pulizia diretta deve in genere essere eseguita con solventi blandi per non danneggiare la vernice.

Ad essa è poi fatta seguire una pronta risciacquatura, eseguita di solito con lo stesso olio utilizzato nel funzionamento effettivo. E' buona norma eseguire questa operazione con olio caldo, eliminando cioè l'eventuale refrigerante dal circuito. Occorre in questo caso tenere sotto particolare controllo l'eventuale formazione di schiuma, che è resa più agevole dalla presenza di impurità. Alla fine dell'operazione, si scarica l'olio possibilmente ancora caldo.

L'efficienza della lubrificazione dipende, oltre che dalle caratteristiche dell'olio, anche dalla regolarità del suo arrivo ai punti stabiliti.

STOCCAGGIO

Generalmente, se lo stoccaggio dei riduttori avrà una durata relativamente breve (fino a 6 mesi massimo), è sufficiente scegliere un ambiente chiuso, pulito, secco ed esente da vibrazioni eccessive, per non danneggiare i cuscinetti; inoltre, esso dovrà essere a temperatura normale, inclusa fra 0 °C e 40 °C.

In caso invece di lungo stoccaggio, i riduttori dovranno essere mantenuti in ambienti esenti da umidità o da polvere e, qualora non sia totalmente possibile provvedere un ambiente di caratteristiche ottimali, si deve far uso di sostanze protettive per gli alberi, i giunti ed il flangiamme in generale.

Nel caso i riduttori debbano rimanere a lungo inattivi in ambiente con elevata percentuale di umidità, è necessario riempirli totalmente di olio; naturalmente il livello corretto dovrà essere ripristinato quando i gruppi saranno messi in funzione.

LIVELLI SONORI

I riduttori OT, PL e PD si segnalano anche per i livelli di rumorosità piuttosto contenuta, in virtù della costruzione compatta, dell'elevata precisione costruttiva e dell'ottimale progettazione e costruzione degli ingranaggi.

LUBRIFICAZIONE

Tutti i riduttori OT, PL e PD provvisti di precoppia (OT../3, PL../3, e PD../3) vengono da noi forniti con la precoppia già lubrificata e quindi non richiedono alcun riempimento da parte dei clienti.

Viene utilizzato l'olio minerale tipo ISO VG 220 (vedi tabella 1).

Il corpo della grandezza 56 è lubrificato con lo stesso olio minerale.

Gli OT, PL e PD a due stadi di riduzione, così come la carcassa principale nei riduttori con precoppia vengono invece forniti privi di olio, e la relativa lubrificazione è a cura dei clienti.

4 – Cleaning

Direct cleaning must be usually carried out with soft solvents in order not to damage painting.

It must be followed by a prompt rinsing, effected with the same oil of the normal use. It is preferable to carry out this operation with hot oil, removing the coolant of the circuit, if there is any.

It must be accurately prevented the potential foam formation, made easier by the presence of dirt.

At the end of the operation, oil is discharged possibly still hot.

The efficiency of the lubrication, in addition to oil properties, depends on the regularity by which oil reaches the stated points.

STOCKING

Generally, if stocking of gearboxes lasts a relatively short time (up to 6 months max.) it is sufficient to choose a closed, clean and dry environment, free of excessive vibrations, in order not to damage bearings. Moreover, said environment must be at a normal temperature, included between 0 °C and 40 °C. On the contrary, in case of a long time of stocking, gearboxes must be kept in an environment free of moisture and dust, and if it is not possible to provide an environment with excellent features, it must be provided the use of suitable protective means for shafts, couplings and flanges in general, in order to prevent rust and corrosion. If gearboxes must be kept inactive for a long time in an environment with high humidity, it is necessary to fill them entirely with oil: of course, the correct level of lubricant will have to be restored when groups are started up.

SOUND LEVEL

The performance of OT, PL and PD gearboxes in terms of noise reduction is excellent due to the compact building design, the high constructive precision and the optimum gear machining.

LUBRICATION

All OT, PL and PD gearboxes provided with the primary reduction (OT../3, PL../3, and PD../3) are supplied with the primary reduction already pre-lubricated in-house, and therefore do not require any filling with oil by the customer.

It is used mineral oil type ISO VG 220 (see chart 1).

The body (size 56) is lubricated with the same type of mineral oil.

On the contrary, OT, PL and PD gearboxes with 2 stages of reduction, as well as the main housing in the versions with primary reduction are supplied without oil, and the relative lubrication is at customer's account.

4 - Reinigung

Dieser Vorgang wird vorzugsweise bei Betriebstemperatur durchgeführt.

Das warme Öl wird abgelassen und anschließend das Innere des Getriebes mit einem nicht aggressiven Lösungsmittel abgewaschen, um den Lack nicht zu beschädigen. Danach spült man das Getriebe mit dem vorgesehenen Schmieröl durch. Verunreinigungen im Schmiermittel bzw. im Getriebe können zur Verseifung und Schaumbildung führen. Am Ende des Reinigungsvorgangs wird das zur Spülung verwendete Öl möglichst im warmen Zustand abgelassen und das Getriebe mit neuem Öl befüllt. Eine gute Schmierung hängt sowohl von der Ölcharakteristik als auch von der Verteilung an den zu schmierenden Teilen ab.

LAGERUNG

Erfolgt die Lagerung der Getriebe nur für einen kurzen Zeitraum von maximal 6 Monaten, so reicht es, wenn die Getriebe in einer trockenen, sauberen, abgeschlossenen, vibrationsfreien und von aggressiven chemischen Dämpfen freien Umgebung bei einer Temperatur zwischen 0 °C und 40 °C abgestellt werden.

Bei einer langfristigen Lagerung hingegen müssen die Getriebe in staubfreien Räumen ohne jegliche Feuchtigkeit gelagert werden.

Wenn diese optimalen Voraussetzungen nicht eingehalten werden können, müssen Wellen, Kupplungen und allgemeine Flansche durch Oberflächenschutzmittel geschützt werden.

Bei längerer Lagerung der Getriebe in feuchten Räumen empfiehlt es sich, zusätzlich das Getriebe voll mit Öl zu befüllen.

Selbstverständlich muß vor der Inbetriebnahme der vorgeschriebene Ölstand wiederhergestellt werden.

GERÄUSCHPEGEL

Die OT, PL und PD Getriebe zeichnen sich auch in Bezug auf den niedrigen Geräuschpegel durch ihre kompakte Bauform, hohe Fertigungspräzision und optimale Verzahnungsgeometrie aus.

SCHMIERUNG

Bei allen Getrieben der Type OT, PL und PD mit Vorstufe (OT../3, PL../3 und PD../3), wird die Vorstufe bereits vom Hersteller aus mit Schmiermittel geliefert, so daß von Kundenseite her kein zusätzliches Schmiermittel in die Vorstufe einzufüllen ist. Hierbei wird ein Mineralöl von Shell der Type ISO VG 220 verwendet (siehe Tabelle 1).

Der Körper der Größenversion 56 ist mit Mineralöl vom Typ ISO VG 220 geschmiert.

Die zweistufigen OT, PL und PD Getriebe sowie die Hauptgehäuse der Vorstufenge triebe werden alle ohne jegliches Schmiermittel geliefert. Es ist somit Aufgabe des Kunden, diese vor der Inbetriebnahme mit Öl zu füllen.

Si raccomanda di attenersi scrupolosamente alle tabelle dei lubrificanti qui sotto indicati:

We recommend to strictly adhere to the table of lubricants mentioned here below:

Grundsätzlich empfiehlt es sich die nachfolgenden Schmiermittel zu verwenden:

TABELLA 1 – LUBRIFICANTI MINERALI

TABLE 1 - MINERAL LUBRICANTS

TABELLE 1 - MINERALSCHMIERMITTEL

MARCA / MAKE / HERSTELLER	TIPO DI OLIO / TYPE OF OIL / ÖLSORTE
<ul style="list-style-type: none"> • IP • SHELL • MOBIL • ESSO 	MELLANA OIL 220 OMALA OIL 220 MOBILGEAR 630 SPARTAN EP220

TEMPERATURA AMBIENTE / AMBIENT TEMPERATURE / UMGEBUNGSTEMPERATUR - 5 °C ÷ + 35 °C
 TEMPERATURA OPERATIVA / OPERATING TEMPERATURE / BETRIEBSTEMPERATUR - 5 °C ÷ + 80 °C

TABELLA 2 – LUBRIFICANTI SINTETICI

TABLE 2 - SYNTHETIC LUBRICANTS

TABELLE 2 - SYNTHETISCHE SCHMIERMITTEL

MARCA / MAKE / HERSTELLER	TIPO DI OLIO / TYPE OF OIL / ÖLSORTE
<ul style="list-style-type: none"> • IP • SHELL • KLÜBER 	TELIUM OIL 320 TIVELA OIL SC 320 SYNTHESO D 320 EP

TEMPERATURA AMBIENTE / AMBIENT TEMPERATURE / UMGEBUNGSTEMPERATUR - 30 °C ÷ + 50 °C
 TEMPERATURA OPERATIVA / OPERATING TEMPERATURE / BETRIEBSTEMPERATUR - 40 °C ÷ + 130 °C

Gli anelli di tenuta, costruiti in mescole nitriliche, non consentono però di operare soddisfacentemente a temperatura superiore a + 85 °C.

Nell'ipotesi che la temperatura all'interno del riduttore possa raggiungere livelli più elevati di + 85 °C per tempi significativi, è necessario richiederci l'esecuzione speciale con anelli di tenuta in mescole fluorurate (viton).

E' fondamentale accertarsi della quantità di lubrificante richiesta per la specifica posizione di montaggio che è prevista, dal momento che la quantità di olio necessaria può differire in funzione della posizione di utilizzo.

A riempimento avvenuto, accertarsi di porre i tappi di riempimento, livello e scarico olio nelle corrette collocazioni per la posizione di montaggio prescelta.

Precisarci sempre la posizione di montaggio se si desidera che i tappi vengano già posti nelle giuste collocazioni da noi.

NOTA BENE: Gli oli sintetici suggeriti sopra garantiscono una durata a vita senza necessità di alcuna manutenzione.

E' tuttavia opportuno controllare , attraverso il tappo di livello trasparente, collocato nella giusta posizione, se il livello dell'olio si mantiene corretto e non si verificano anomalie, come potrebbe essere determinato da sia pure molto improbabili perdite di olio attraverso gli anelli di tenuta.

In caso di occasionali necessità di ripristino del giusto livello, utilizzare lo stesso olio già presente nel riduttore.

Le posizioni di montaggio degli OT, PL e PD sono importanti per individuare la corretta quantità di lubrificante da introdurre e per la corretta posizione dei tappi.

Seals, being made in nitrile rubber compounds, do not allow to operate satisfactorily at temperatures over + 85 °C. In the assumption temperature inside the gearbox achieves higher values than + 85 °C for a significant period of time, it is necessary to require the special execution provided with special seals in fluorurated compounds (viton).

It is essential to make sure that the oil quantity is the correct one for the expected assembling position, considering that oil quantity might differ for the different positions of use.

After oil filling, make sure that filling, level and discharge plugs are positioned correctly in view of the assembling position.

Please let us know the assembly position, if it is wished that plugs are placed in the correct location at the time of delivery.

N.B.: Synthetic oils suggested here above assure that the expected lifetime is reached without any need of maintenance.

It is however convenient to check through the proper transparent oil level plug that the oil level keeps at the correct value and no failures have occurred, as it could happen in case of unlikely leaks.

In case of occasional needs to restore the correct level, the same type of oil must be used.

OT, PL and PD assembling positions are important not for starting the correct oil quantity, but even for finding the correct plug positions.

Die Wellendichtringe aus Nitrilmischungen (Standard) vertragen eine Betriebstemperatur von maximal 85 °C. Bei höheren Betriebstemperaturen ab 85 °C über einen längeren Zeitraum hinweg, sollten spezielle Wellendichtringe aus Fluoridmischungen (Viton) eingesetzt werden.

Da die Ölmenge von der Einbaulage abhängt, muß diese vorher festgelegt werden, um die erforderliche Ölmenge einzufüllen.

Nach Einfüllung des Schmiermittels ist zu prüfen, ob die Ölschrauben (Ölstands-, Ölblaß- und Ölfüllschrauben) an den vorgeschriebenen Stellen sitzen.

Ist die Einbaulage bei der Bestellung bekannt, so werden die Ölschrauben direkt vom Hersteller positioniert.

Bemerkung:

Die oben empfohlenen Synthetikölsorten gewähren eine Lebensdauerschmierung, also eine nahezu wartungsfreie Schmierung.

Es ist jedoch ratsam, von Zeit zu Zeit den Ölstand durch das Ölstandsauge zu kontrollieren.

So können Anomalien, die z.B. durch Wellendichtringe auftreten können, verhindert werden.

Im Falle daß Öl, nachgefüllt werden muß, ist die gleiche Ölsorte zu verwenden.

Bei den Getrieben OT, PL und PD ist die Einbaulage wichtig, damit die richtige Ölmenge eingefüllt und die Ölschrauben korrekt angebracht werden.

QUANTITA' DI LUBRIFICANTE
OT e OT../3

LUBRICANT QUANTITY
OT and OT../3

ÖLMENGE
OT und OT../3

	Posiz. di mont. Mounting position Einbaulage	OT.. - OT../3					
		Carcassa principale / Main housing / Hauptgehäuse					
		56	63	80	100	125	160
Olio (litri) Oil (liters) Öl (Liter)	B3 - B7	0.8	0.9	1.4	2.6	5.6	9.5
	B6	0.8	0.9	1.4	2.6	5.6	9.5
	B8	0.9	1.1	1.6	3.2	6.5	11.0
	V5 - V6	0.9	1	1.5	3.0	5.8	10.5

OT../3					
56	63	80	100	125	160

Precoppia per OT../3 già lubrificata dalla SITI
Primary reduction OT../3 prelubricated by SITI
Vorstufe OT../3 geschmiert bei SITI

POSIZIONI DI MONTAGGIO

MOUNTING POSITIONS

EINBAULAGE

OT..

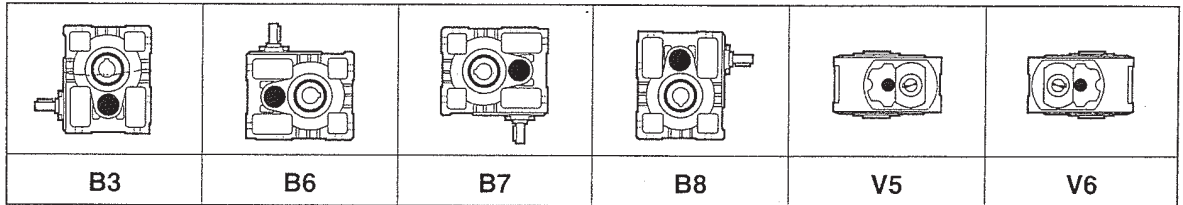

OT../3

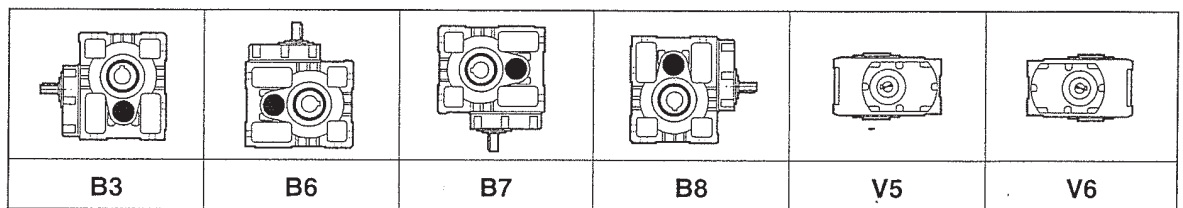

QUANTITA' DI LUBRIFICANTE
PL e PL../3

LUBRICANT QUANTITY
PL and PL../3

ÖLMENGE
PL und PL../3

	Posiz. di mont. Mounting position Einbaulage	PL..				
		Carcassa principale / Main housing / Hauptgehäuse				
		63	80	100	125	160
Olio (litri) Oil (liters) Öl (Liter)	B3 - B8	0.9	1.5	2.8	5.6	10
	B6	1.4	2.1	4.0	7.6	12.5
	B7	1.1	1.8	3.6	7.0	11.7
	V5 - V6	1.2	1.9	3.8	7.2	12.0

PL../3					
63	80	100	125	160	
0.2	0.3	0.4	0.6	0.8	

Precoppia su PL../3 già lubrificata dalla SITI
Primary reduction PL../3 prelubricated by SITI
Vorstufe PL../3 geschmiert bei SITI

POSIZIONI DI MONTAGGIO

MOUNTING POSITIONS

EINBAULAGE

PL
PL../3

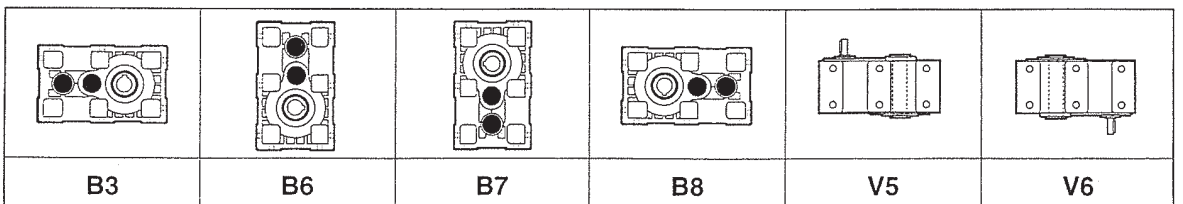

QUANTITA' DI LUBRIFICANTE
PD e PD../3

LUBRICANT QUANTITY
PD and PD../3

ÖLMENGE
PD und PD../3

	Posiz. di mont. Mounting position Einbaulage	PD..				
		Carcassa principale / Main housing / Hauptgehäuse				
		63	80	100	125	160
Olio (litri) Oil (liters) Öl (Liter)	B3	1.1	1.6	2.8	5.5	10
	B6 - B7	0.8	1.4	2.6	5.3	9.8
	B8	1.0	1.7	3.5	6.6	11.2
	V5 - V6	1.1	1.8	3.6	6.8	11.6

PD../3					
63	80	100	125	160	
0.2	0.3	0.4	0.6	0.8	

Precoppia su PD../3 già lubrificata dalla SITI
Primary reduction PD../3 prelubricated by SITI
Vorstufe PD../3 geschmiert bei SITI

POSIZIONI DI MONTAGGIO

MOUNTING POSITIONS

EINBAULAGE

PD
PD../3

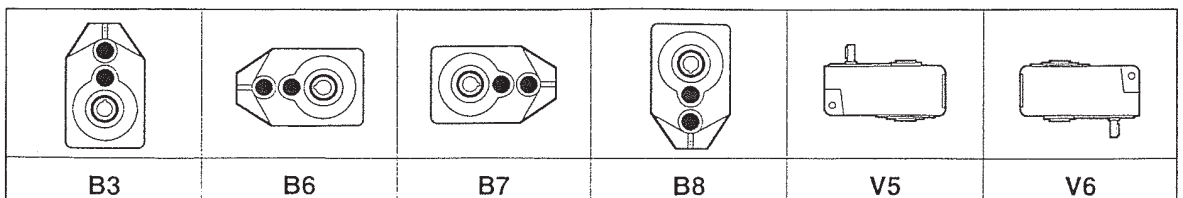

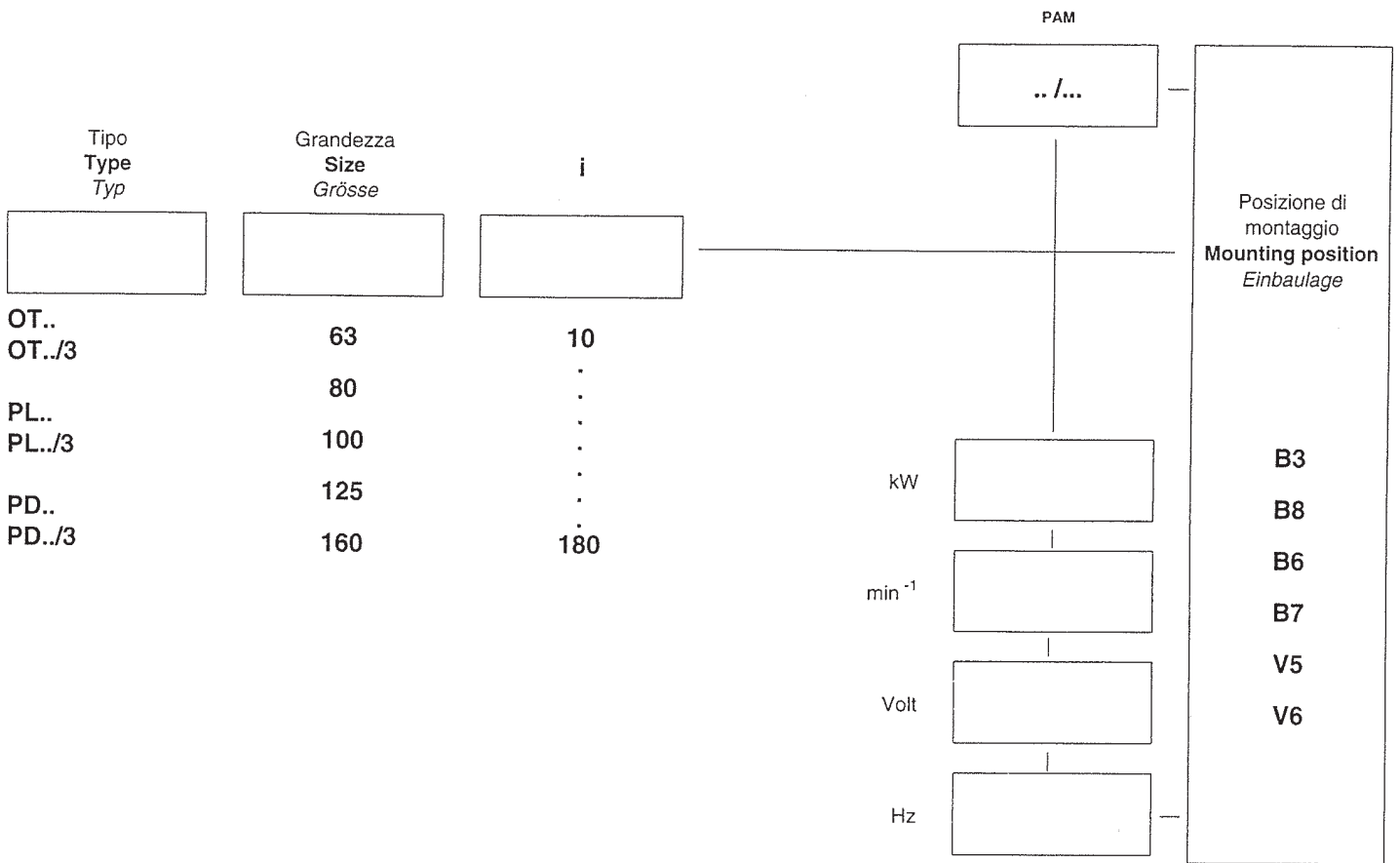

Precisare eventuali particolarità:
Clarify possible options:
Eventuelle Sonderausführungen zeigen:

ALBERO LENTO SEMPLICE
SINGLE OUTPUT SHAFT
 EINSEITIGE STECKWELLE

ALBERO LENTO DOPPIO
DOUBLE OUTPUT SHAFT
 DOPPELSEITIGE STECKWELLE

FLANGIA USCITA
OUTPUT FLANGE
 ABTRIEBSFLANSCH

ETC...

OT..

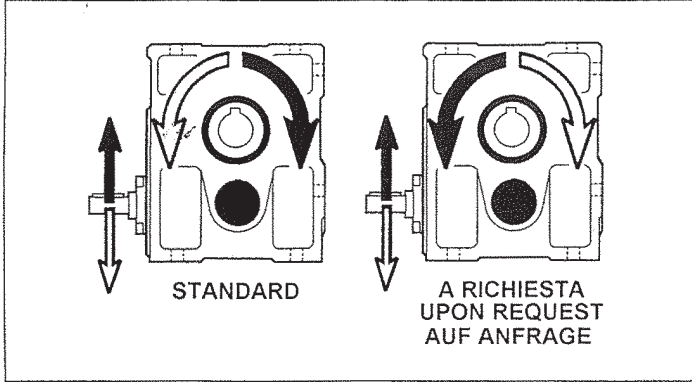

OT../3

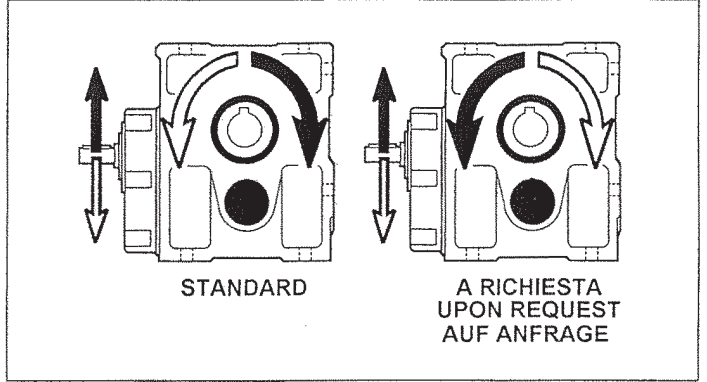

PL..

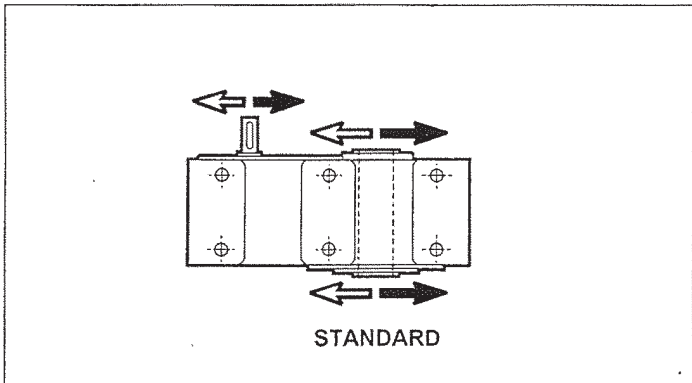

PL../3

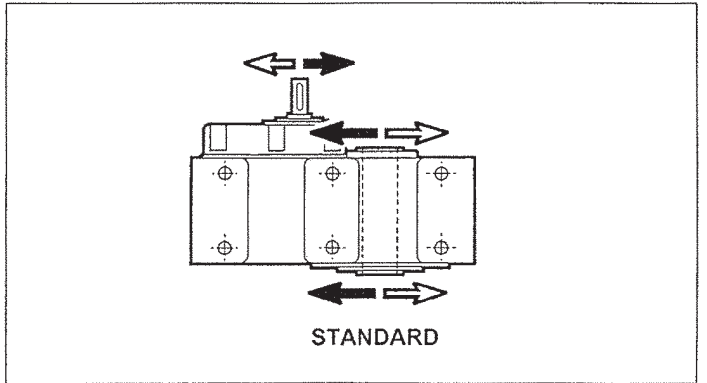

PD..

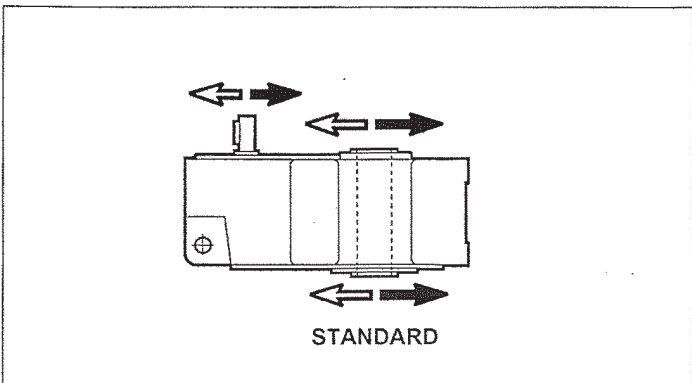

PD../3

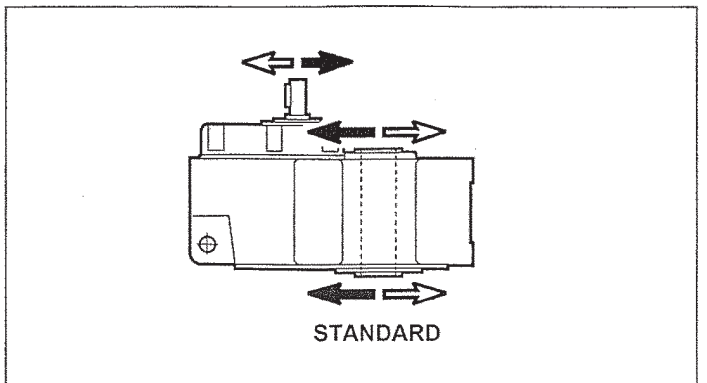

PRESTAZIONI
PERFORMANCES
LEISTUNG

OT..
OT../3

	Pag. Page <i>Seite</i>
OT 56, MOT 56	16
OT 56/3, MOT 56/3	17
OT 63, MOT 63	18
OT 63/3, MOT 63/3	19
OT 80, MOT 80	20
OT 80/3, MOT 80/3	21
OT 100, MOT 100	22
OT 100/3, MOT 100/3	23
OT 125, MOT 125	24
OT 125/3, MOT 125/3	25
OT 160, MOT 160	26
OT 160/3, MOT 160/3	27
CARICHI RADIALI DELLE GRANDEZZE 80, 100, 125, 160 SIZE OVERHUNG LOADS 80, 100, 125, 160 <i>RADIALE BELASTUNGEN DER GRÖSSEN 80, 100, 125, 160</i>	28

i	n ₁	n ₂	M ₂	KW ₁	HP ₁	R.D.
9.83	2800	284,8	99	3,1	4,1	0,96
12,70		220,5	104	2,5	3,3	0,96
14,32		195,5	113	2,4	3,2	0,96
19,65		142,5	117	1,8	2,4	0,96
25,40		110,2	122	1,5	2,0	0,96
28,63		97,8	126	1,3	1,8	0,96
38,10		73,5	131	1,1	1,4	0,96
42,95		65,2	135	1,0	1,3	0,96

i	n ₁	n ₂	M ₂	KW ₁	HP ₁	R.D.	fs	P.A.M.
9.83	2800	284,8	48	1,50	2,00	0,96	2,05	80
12,70		220,5	62	1,50	2,00	0,96	1,67	80
14,32		195,5	70	1,50	2,00	0,96	1,61	80
19,65		142,5	97	1,50	2,00	0,96	1,21	80
25,40		110,2	125	1,50	2,00	0,96	0,98	80
28,63		97,8	103	1,10	1,50	0,96	1,22	80
38,10		73,5	94	0,75	1,00	0,96	1,40	71
42,95		65,2	105	0,75	1,00	0,96	1,28	71

9.83	1400	142,4	110	1,7	2,3	0,96
12,70		110,2	115	1,4	1,8	0,96
14,32		97,8	125	1,3	1,8	0,96
19,65		71,2	130	1,0	1,3	0,96
25,40		55,1	135	0,8	1,1	0,96
28,63		48,9	140	0,7	1,0	0,96
38,10		36,7	145	0,6	0,8	0,96
42,95		32,6	150	0,5	0,7	0,96

9.83	1400	142,4	48	0,75	1,00	0,96	2,28	80
12,70		110,2	62	0,75	1,00	0,96	1,84	80
14,32		97,8	70	0,75	1,00	0,96	1,78	80
19,65		71,2	97	0,75	1,00	0,96	1,35	80
25,40		55,1	125	0,75	1,00	0,96	1,08	80
28,63		48,9	103	0,55	0,75	0,96	1,36	80
38,10		36,7	92	0,37	0,50	0,96	1,57	71
42,95		32,6	104	0,37	0,50	0,96	1,44	71

9.83	900	91,6	121	1,2	1,6	0,96
12,70		70,9	127	1,0	1,3	0,96
14,32		62,8	138	0,9	1,3	0,96
19,65		45,8	143	0,7	1,0	0,96
25,40		35,4	149	0,6	0,8	0,96
28,63		31,4	154	0,5	0,7	0,96
38,10		23,6	160	0,4	0,5	0,96
42,95		21,0	165	0,4	0,5	0,96

9.83	900	91,6	55	0,55	0,75	0,96	2,20	80
12,70		70,9	71	0,55	0,75	0,96	1,78	80
14,32		62,8	80	0,55	0,75	0,96	1,72	80
19,65		45,8	110	0,55	0,75	0,96	1,30	80
25,40		35,4	142	0,55	0,75	0,96	1,05	80
28,63		31,4	108	0,37	0,50	0,96	1,43	80
38,10		23,6	97	0,25	0,33	0,96	1,65	71
42,95		21,0	109	0,25	0,33	0,96	1,51	71

DIMENSIONI DI INGOMBRO

OVERALL DIMENSIONS

ALLGEMEINE ABMESSUNGEN

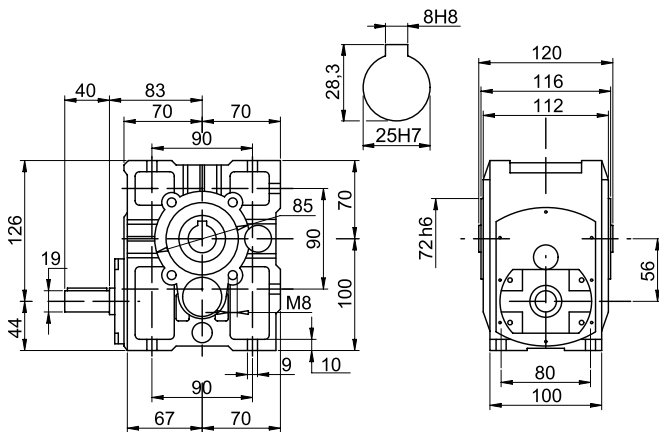

OT 56 = 12

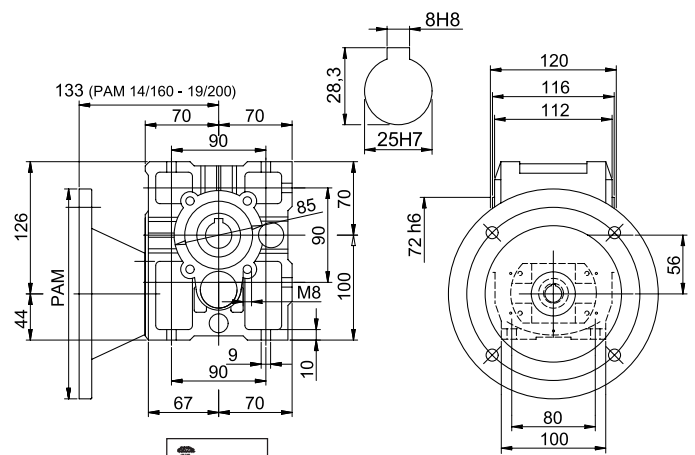

MOT 56 = 14

CARICHI RADIALI (N)

OVERHUNG LOADS (N)

RADIALE BELASTUNGEN (N)

ALBERO VELOCE/INPUT SHAFT/EINGANGSWELLE		
	OT 56	OT 56/3
1400 min ⁻¹	350	250

ALBERO LENTO/OUTPUT SHAFT/EINGANGSWELLE							
OT 56 - OT 56/3							
min ⁻¹	0°	30°	60°	90°	120°	150°	180°
20	7732	7794	8675	9721	10922	11862	12232
40	5847	6112	6738	7784	8988	9979	10349
60	4965	5174	5802	6846	8049	9040	9458
80	4337	4547	5174	6220	7422	8467	8832
100	3919	4129	4702	5744	6948	7980	8413
120	3605	3763	4389	5383	6638	7682	8100
140	3345	3491	4073	4995	6159	7128	7516
160	3135	3272	3817	4682	5773	6681	7045

Rotazione oraria
Clockwise rotation
Uhrzeigersinn

Rotazione antioraria
Anticlockwise rotation
Gegenuhrzeigersinn

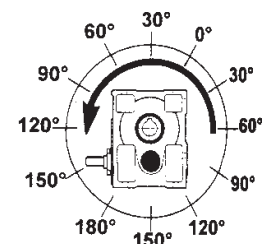
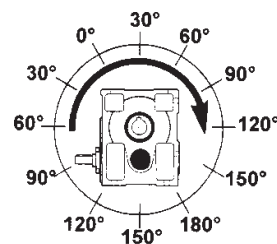

i	n ₁	n ₂	M ₂	KW ₁	HP ₁	R.D.
53,72	2800	52,1	135	0,8	1,1	0,92
60,56		46,2	135	0,7	0,9	0,92
65,15		43,0	135	0,7	0,9	0,92
75,60		37,0	135	0,6	0,8	0,92
80,58		34,7	144	0,6	0,8	0,92
90,84		30,8	149	0,5	0,7	0,92
95,63		29,3	153	0,5	0,7	0,92
110,17		25,4	153	0,4	0,6	0,92
143,44		19,5	158	0,4	0,5	0,92
161,72		17,3	162	0,3	0,4	0,92

i	n ₁	n ₂	M ₂	KW ₁	HP ₁	R.D.	fs	P.A.M.
53,72	2800	52,1	126	0,75	1,00	0,92	1,07	71
60,56		46,2	143	0,75	1,00	0,92	0,95	71
65,15		43,0	51	0,25	0,33	0,92	2,64	63
75,60		37,0	59	0,25	0,33	0,92	2,28	63
80,58		34,7	139	0,55	0,75	0,92	1,04	71
90,84		30,8	157	0,55	0,75	0,92	0,95	71
95,63		29,3	75	0,25	0,33	0,92	2,04	63
110,17		25,4	86	0,25	0,33	0,92	1,77	63
143,44		19,5	113	0,25	0,33	0,92	1,40	63
161,72		17,3	127	0,25	0,33	0,92	1,28	63

53,72	1400	26,1	150	0,4	0,6	0,92
60,56		23,1	150	0,4	0,5	0,92
65,15		21,5	150	0,4	0,5	0,92
75,60		18,5	150	0,3	0,4	0,92
80,58		17,4	160	0,3	0,4	0,92
90,84		15,4	165	0,3	0,4	0,92
95,63		14,6	170	0,3	0,4	0,92
110,17		12,7	170	0,2	0,3	0,92
143,44		9,8	175	0,2	0,3	0,92
161,72		8,7	180	0,2	0,2	0,92

53,72	1400	26,1	125	0,37	0,50	0,92	1,20	71
60,56		23,1	141	0,37	0,50	0,92	1,07	71
65,15		21,5	74	0,18	0,25	0,92	2,04	63
75,60		18,5	85	0,18	0,25	0,92	1,76	63
80,58		17,4	126	0,25	0,33	0,92	1,27	71
90,84		15,4	143	0,25	0,33	0,92	1,16	71
95,63		14,6	108	0,18	0,25	0,92	1,57	63
110,17		12,7	124	0,18	0,25	0,92	1,37	63
143,44		9,8	162	0,18	0,25	0,92	1,08	63
161,72		8,7	183	0,18	0,25	0,92	0,99	63

53,72	900	16,8	165	0,3	0,4	0,92
60,56		14,9	165	0,3	0,4	0,92
65,15		13,8	165	0,3	0,3	0,92
75,60		11,9	165	0,2	0,3	0,92
80,58		11,2	176	0,2	0,3	0,92
90,84		9,9	182	0,2	0,3	0,92
95,63		9,4	187	0,2	0,3	0,92
110,17		8,2	187	0,2	0,2	0,92
143,44		6,3	193	0,1	0,2	0,92
161,72		5,6	198	0,1	0,2	0,92

53,72	900	16,8	131	0,25	0,33	0,92	1,26	71
60,56		14,9	148	0,25	0,33	0,92	1,12	71
65,15		13,8	76	0,12	0,16	0,92	2,16	63
75,60		11,9	89	0,12	0,16	0,92	1,86	63
80,58		11,2	197	0,25	0,33	0,92	0,89	71
90,84		9,9	160	0,18	0,25	0,92	1,14	71
95,63		9,4	112	0,12	0,16	0,92	1,67	63
110,17		8,2	129	0,12	0,16	0,92	1,45	63
143,44		6,3	168	0,12	0,16	0,92	1,15	63
161,72		5,6	189	0,12	0,16	0,92	1,05	63

DIMENSIONI DI INGOMBRO

OVERALL DIMENSIONS

ALLGEMEINE ABMESSUNGEN

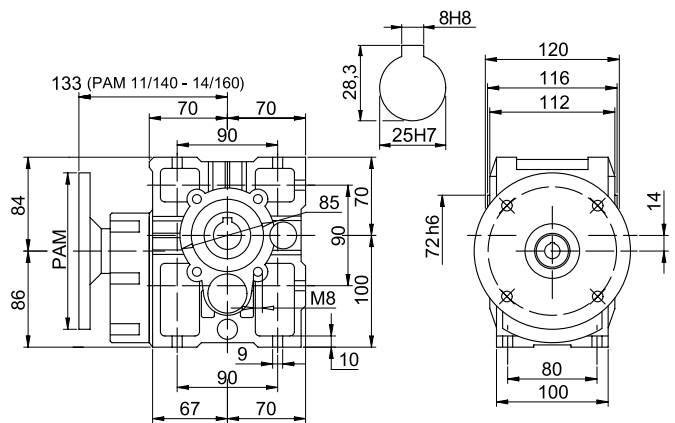
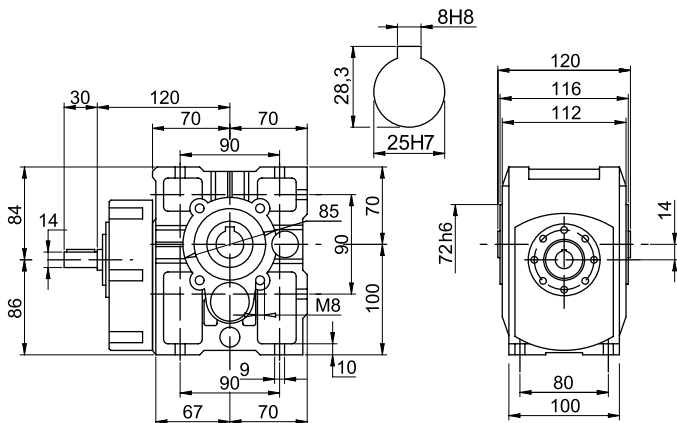

OT 56/3

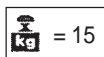

MOT 56/3

i	n ₁	n ₂	M ₂	KW ₁	HP ₁	R.D.
10,16	2800	275,6	180	5,4	7,2	0,96
13,08		214,1	180	4,2	5,6	0,96
14,38		194,7	180	3,8	5,1	0,96
20,31		137,9	216	3,2	4,3	0,96
26,15		107,1	207	2,4	3,2	0,96
28,75		97,4	207	2,2	2,9	0,96
41,07		68,2	207	1,5	2,1	0,96
51,19		54,7	180	1,1	1,4	0,96

i	n ₁	n ₂	M ₂	KW ₁	HP ₁	R.D.	fs	P.A.M.	
10,16	2800	275,6	73	2,20	3,00	0,96	2,46	80	90
13,08		214,1	94	2,20	3,00	0,96	1,91	80	90
14,38		194,7	104	2,20	3,00	0,96	1,74	80	90
20,31		137,9	146	2,20	3,00	0,96	1,48	80	90
26,15		107,1	188	2,20	3,00	0,96	1,10	80	90
28,75		97,4	207	2,20	3,00	0,96	1,00	80	90
41,07		68,2	148	1,10	1,50	0,96	1,40	80	
51,19		54,7	184	1,10	1,50	0,96	0,98	80	

10,16	1400	137,8	200	3,0	4,0	0,96
13,08		107,0	200	2,3	3,1	0,96
14,38		97,4	200	2,1	2,8	0,96
20,31		68,9	240	1,8	2,4	0,96
26,15		53,5	230	1,3	1,8	0,96
28,75		48,7	230	1,2	1,6	0,96
41,07		34,1	230	0,9	1,1	0,96
51,19		27,3	200	0,6	0,8	0,96

10,16	1400	137,8	120	1,80	2,50	0,96	1,67	80	90
13,08		107,0	154	1,80	2,50	0,96	1,30	80	90
14,38		97,4	170	1,80	2,50	0,96	1,18	80	90
20,31		68,9	239	1,80	2,00	0,96	1,00	80	90
26,15		53,5	257	1,50	2,00	0,96	0,90	80	90
28,75		48,7	207	1,10	1,50	0,96	1,11	80	90
41,07		34,1	202	0,75	1,00	0,96	1,14	80	
51,19		27,3	251	0,75	1,00	0,96	0,80	80	

10,16	900	88,6	220	2,1	2,8	0,96
13,08		68,8	220	1,7	2,2	0,96
14,38		62,6	220	1,5	2,0	0,96
20,31		44,3	264	1,3	1,7	0,96
26,15		34,4	253	0,9	1,3	0,96
28,75		31,3	253	0,9	1,2	0,96
41,07		21,9	253	0,6	0,8	0,96
51,19		17,6	220	0,4	0,6	0,96

10,16	900	88,6	114	1,10	1,50	0,96	1,93	80	90
13,08		68,8	147	1,10	1,50	0,96	1,50	80	90
14,38		62,6	161	1,10	1,50	0,96	1,37	80	90
20,31		44,3	228	1,10	1,50	0,96	1,16	80	90
26,15		34,4	200	0,75	1,00	0,96	1,27	80	90
28,75		31,3	220	0,75	1,00	0,96	1,15	80	90
41,07		21,9	230	0,55	0,75	0,96	1,10	80	
51,19		17,6	287	0,55	0,75	0,96	0,77	80	

DIMENSIONI DI INGOMBRO

OVERALL DIMENSIONS

ALLGEMEINE ABMESSUNGEN

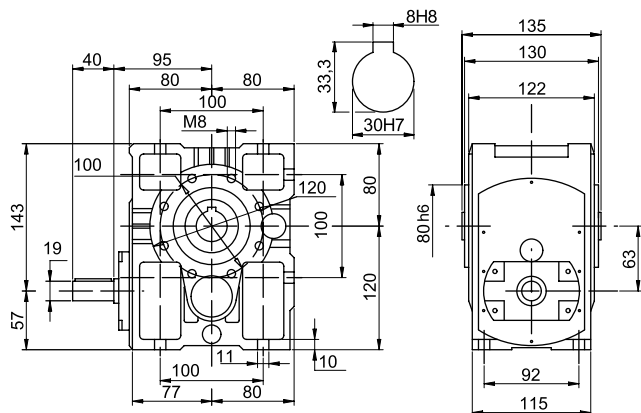
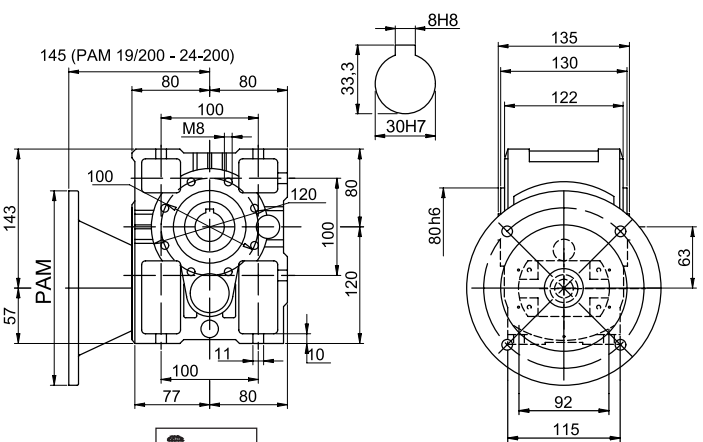
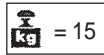
OT 63

MOT 63

CARICHI RADIALI (N)

OVERHUNG LOADS (N)

RADIALE BELASTUNGEN (N)

ALBERO VELOCE/INPUT SHAFT/EINGANGSWELLE		
1400 min ⁻¹	OT 63	OT 63/3
		550

 Rotazione oraria
 Clockwise rotation
 Uhrzeigersinn

 Rotazione antioraria
 Anticlockwise rotation
 Gegenuhrzeigersinn

ALBERO LENTO/OUTPUT SHAFT/EINGANGSWELLE							
OT 63 - OT 63/3							
min ⁻¹	0°	30°	60°	90°	120°	150°	180°
20	9205	9517	10327	11572	13002	14121	14562
40	6961	7276	8022	9267	10700	11880	12320
60	5911	6159	6907	8150	9582	10762	11259
80	5164	5413	6159	7404	8836	10079	10514
100	4666	4916	5598	6838	8271	9500	10016
120	4291	4480	5225	6409	7902	9145	9643
140	3982	4156	4848	5946	7332	8486	8948
160	3732	3896	4544	5574	6872	7954	8386

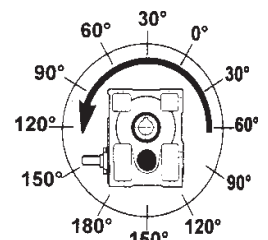
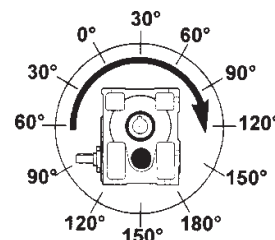

i	n ₁	n ₂	M ₂	KW ₁	HP ₁	R.D.
16,54	2800	169,3	216	4,2	5,5	0,92
21,30		131,5	243	3,6	4,8	0,92
23,41		119,6	234	3,2	4,2	0,92
33,08		84,6	252	2,4	3,2	0,92
42,59		65,7	270	2,0	2,7	0,92
46,82		59,8	252	1,7	2,3	0,92
58,36		48,0	198	1,1	1,4	0,92
94,84		29,5	234	0,8	1,0	0,92
104,26		26,9	234	0,7	1,0	0,92
129,95		21,5	207	0,5	0,7	0,92
147,86		18,9	243	0,5	0,7	0,92
184,30		15,2	216	0,4	0,5	0,92

i	n ₁	n ₂	M ₂	KW ₁	HP ₁	R.D.	fs	P.A.M.	
16,54	2800	169,3	78	1,50	2,00	0,92	2,77	71	80
21,30		131,5	100	1,50	2,00	0,92	2,42	71	80
23,41		119,6	110	1,50	2,00	0,92	2,12	71	80
33,08		84,6	156	1,50	2,00	0,92	1,62	71	80
42,59		65,7	200	1,50	2,00	0,92	1,35	71	80
46,82		59,8	220	1,50	2,00	0,92	1,14	71	80
58,36		48,0	201	1,10	1,50	0,92	0,98	71	80
94,84		29,5	223	0,75	1,00	0,92	1,05	71	
104,26		26,9	180	0,55	0,75	0,92	1,30	71	
129,95		21,5	151	0,37	0,50	0,92	1,37	71	
147,86		18,9	172	0,37	0,50	0,92	1,42	63	71
184,30		15,2	214	0,37	0,50	0,92	1,01	63	71

16,54	1400	84,6	240	2,3	3,1	0,92
21,30		65,7	270	2,0	2,7	0,92
23,41		59,8	260	1,8	2,4	0,92
33,08		42,3	280	1,3	1,8	0,92
42,59		32,9	300	1,1	1,5	0,92
46,82		29,9	280	1,0	1,3	0,92
58,36		24,0	220	0,6	0,8	0,92
94,84		14,8	260	0,4	0,6	0,92
104,26		13,4	260	0,4	0,5	0,92
129,95		10,8	230	0,3	0,4	0,92
147,86		9,5	270	0,3	0,4	0,92
184,30		7,6	240	0,2	0,3	0,92

16,54	1400	84,6	78	0,75	1,00	0,92	3,08	71	80
21,30		65,7	100	0,75	1,00	0,92	2,69	71	80
23,41		59,8	110	0,75	1,00	0,92	2,36	71	80
33,08		42,3	156	0,75	1,00	0,92	1,80	71	80
42,59		32,9	200	0,75	1,00	0,92	1,50	71	80
46,82		29,9	220	0,75	1,00	0,92	1,27	71	80
58,36		24,0	201	0,55	0,75	0,92	1,09	71	80
94,84		14,8	220	0,37	0,50	0,92	1,18	71	
104,26		13,4	242	0,37	0,50	0,92	1,07	71	
129,95		10,8	302	0,37	0,50	0,92	0,76	71	
147,86		9,5	232	0,25	0,33	0,92	1,16	63	71
184,30		7,6	289	0,25	0,33	0,92	0,83	63	71

16,54	900	54,4	264	1,6	2,2	0,92
21,30		42,3	297	1,4	1,9	0,92
23,41		38,4	286	1,3	1,7	0,92
33,08		27,2	308	1,0	1,3	0,92
42,59		21,1	330	0,8	1,1	0,92
46,82		19,2	308	0,7	0,9	0,92
58,36		15,4	242	0,4	0,6	0,92
94,84		9,5	286	0,3	0,4	0,92
104,26		8,6	286	0,3	0,4	0,92
129,95		6,9	253	0,2	0,3	0,92
147,86		6,1	297	0,2	0,3	0,92
184,30		4,9	264	0,1	0,2	0,92

16,54	900	54,4	89	0,55	0,75	0,92	2,97	71	80
21,30		42,3	114	0,55	0,75	0,92	2,60	71	80
23,41		38,4	126	0,55	0,75	0,92	2,28	71	80
33,08		27,2	178	0,55	0,75	0,92	1,73	71	80
42,59		21,1	229	0,55	0,75	0,92	1,44	71	80
46,82		19,2	251	0,55	0,75	0,92	1,23	71	80
58,36		15,4	211	0,37	0,50	0,92	1,15	71	80
94,84		9,5	231	0,25	0,33	0,92	1,24	71	
104,26		8,6	254	0,25	0,33	0,92	1,12	71	
129,95		6,9	317	0,25	0,33	0,92	0,80	71	
147,86		6,1	260	0,18	0,25	0,92	1,14	63	71
184,30		4,9	324	0,18	0,25	0,92	0,82	63	71

DIMENSIONI DI INGOMBRO

OVERALL DIMENSIONS

ALLGEMEINE ABMESSUNGEN

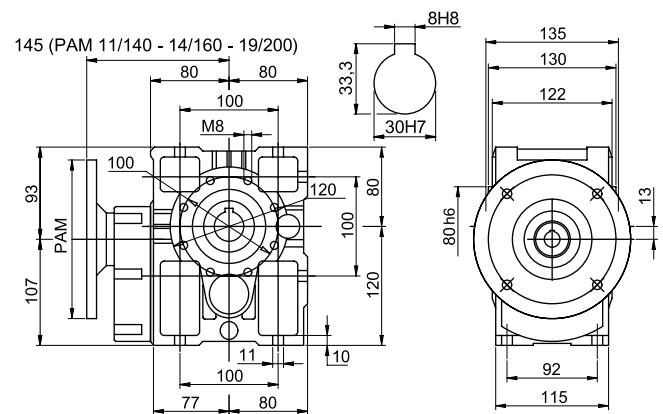
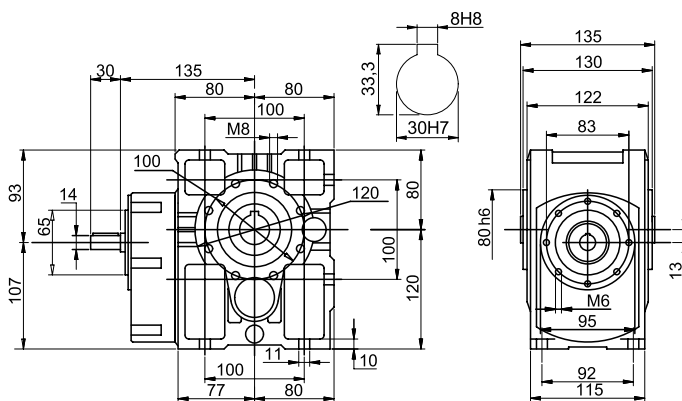
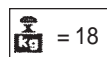
OT 63/3

MOT 63/3

OT 80

PRESTAZIONI

PERFORMANCES

LEISTUNG

MOT 80

i	n ₁	n ₂	M ₂	KW ₁	HP ₁	R.D.
9,53	2800	293,8	398	12,7	17,0	0,96
12,31		227,5	513	12,7	17,0	0,96
15,00		186,7	442	9,0	12,0	0,96
19,06		146,9	451	7,2	9,6	0,96
24,62		113,7	510	6,3	8,4	0,96
30,00		93,3	445	4,5	6,0	0,96
43,33		64,6	408	2,9	3,8	0,96
55,37		50,6	408	2,3	3,0	0,96

i	n ₁	n ₂	M ₂	KW ₁	HP ₁	R.D.	fs	P.A.M.
9,53	2800	293,8	172	5,5	7,5	0,96	2,32	90 100
12,31		227,5	222	5,5	7,5	0,96	2,32	90 100
15,00		186,7	270	5,5	7,5	0,96	1,64	90 100
19,06		146,9	343	5,5	7,5	0,96	1,31	90 100
24,62		113,7	443	5,5	7,5	0,96	1,15	90 100
30,00		93,3	393	4,0	5,5	0,96	1,13	90 100
43,33		64,6	312	2,2	3,0	0,96	1,31	90
55,37		50,6	399	2,2	3,0	0,96	1,02	90

9,53	1400	146,9	468	7,5	10,0	0,96
12,31		113,7	604	7,5	10,0	0,96
15,00		93,3	520	5,3	7,1	0,96
19,06		73,4	530	4,2	5,7	0,96
24,62		56,9	600	3,7	5,0	0,96
30,00		46,7	523	2,7	3,5	0,96
43,33		32,3	480	1,7	2,3	0,96
55,37		25,3	480	1,3	1,8	0,96

9,53	1400	146,9	250	4,0	5,5	0,96	1,87	90 100
12,31		113,7	322	4,0	5,5	0,96	1,87	90 100
15,00		93,3	393	4,0	5,5	0,96	1,32	90 100
19,06		73,4	499	4,0	5,5	0,96	1,06	90 100
24,62		56,9	484	3,0	4,0	0,96	1,24	90 100
30,00		46,7	432	2,2	3,0	0,96	1,21	90 100
43,33		32,3	426	1,5	2,0	0,96	1,13	90
55,37		25,3	399	1,1	1,5	0,96	1,20	90

9,53	900	94,4	515	5,3	7,1	0,96
12,31		73,1	664	5,3	7,1	0,96
15,00		60,0	572	3,7	5,0	0,96
19,06		47,2	583	3,0	4,0	0,96
24,62		36,6	660	2,6	3,5	0,96
30,00		30,0	575	1,9	2,5	0,96
43,33		20,8	528	1,2	1,6	0,96
55,37		16,3	528	0,9	1,2	0,96

9,53	900	94,4	291	3,0	4,0	0,96	1,77	90 100
12,31		73,1	376	3,0	4,0	0,96	1,77	90 100
15,00		60,0	458	3,0	4,0	0,96	1,25	90 100
19,06		47,2	583	3,0	4,0	0,96	1,00	90 100
24,62		36,6	502	2,0	2,7	0,96	1,32	90 100
30,00		30,0	611	2,0	2,7	0,96	0,94	90 100
43,33		20,8	486	1,1	1,5	0,96	1,09	90
55,37		16,3	620	1,1	1,5	0,96	0,85	90

DIMENSIONI DI INGOMBRO

OVERALL DIMENSIONS

ALLGEMEINE ABMESSUNGEN

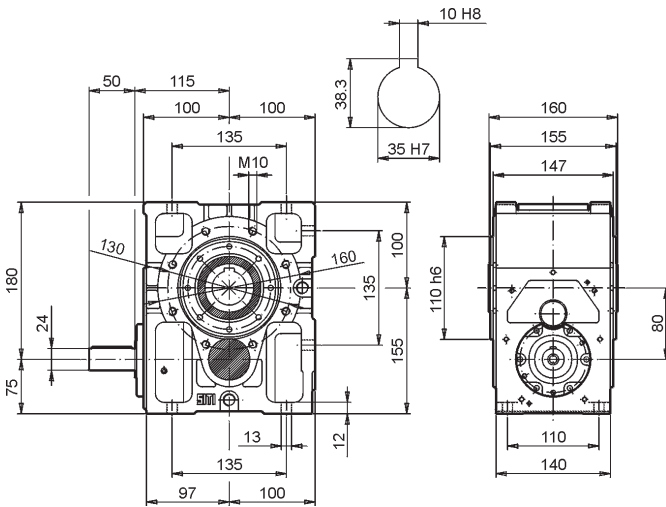

OT 80

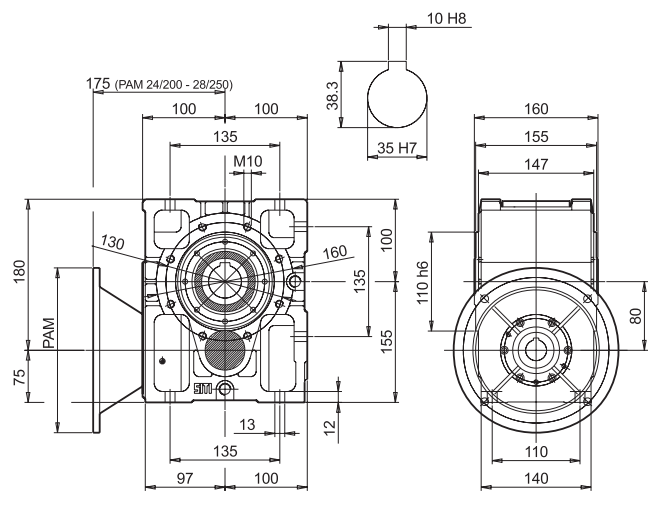
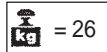

MOT 80

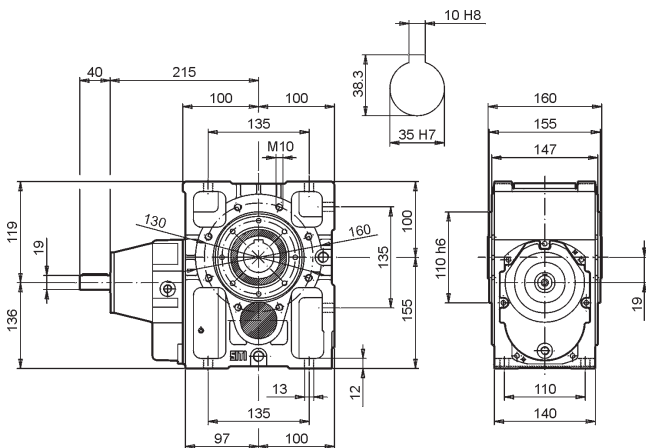
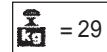

OT 80/3

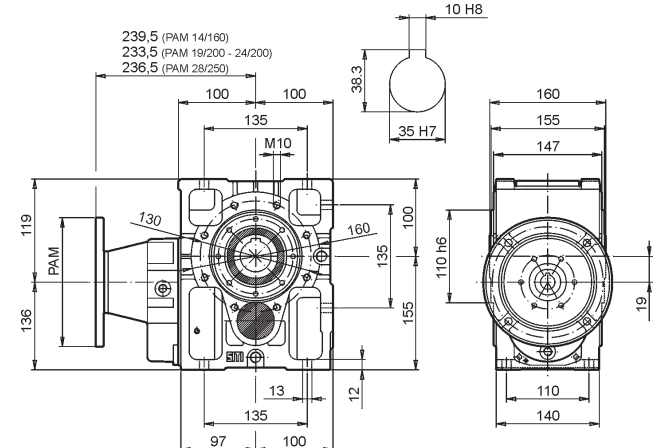
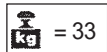

MOT 80/3

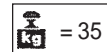

i	n ₁	n ₂	M ₂	KW ₁	HP ₁	R. D.
32,17	2800	87,0	527	5,2	7,0	0,92
38,13		73,4	527	4,4	5,9	0,92
43,14		64,9	527	3,9	5,2	0,92
49,33		56,8	527	3,4	4,5	0,92
57,19		49,0	527	2,9	3,9	0,92
67,45		41,5	527	2,5	3,3	0,92
83,08		33,7	510	2,0	2,6	0,92
98,46		28,4	510	1,7	2,2	0,92
111,41		25,1	510	1,5	1,9	0,92
127,41		22,0	510	1,3	1,7	0,92
147,69		19,0	510	1,1	1,5	0,92
174,2		16,1	510	0,9	1,2	0,92
208,12		13,5	510	0,8	1,0	0,92
233,85		12,0	510	0,7	0,9	0,92
262,57		10,7	510	0,6	0,8	0,92
306,67		9,1	425	0,4	0,6	0,92
366,38		7,6	425	0,4	0,5	0,92
411,67		6,8	425	0,3	0,4	0,92
462,24		6,1	425	0,3	0,4	0,92

i	n ₁	n ₂	M ₂	KW ₁	HP ₁	R. D.	fs	P. A. M.		
32,17	2800	87,0	404	4	5,5	0,92	1,31		90	100
38,13		73,4	479	4	5,5	0,92	1,10	80	90	100
43,14		64,9	406	3	4,0	0,92	1,30	80	90	100
49,33		56,8	341	2,2	3,0	0,92	1,55	80	90	
57,19		49,0	395	2,2	3,0	0,92	1,33	71	80	90
67,45		41,5	466	2,2	3,0	0,92	1,13	71	80	90
83,08		33,7	391	1,5	2,0	0,92	1,30		90	100
98,46		28,4	463	1,5	2,0	0,92	1,10		80	90
111,41		25,1	385	1,1	1,5	0,92	1,33		80	90
127,41		22,0	440	1,1	1,5	0,92	1,16		80	90
147,69		19,0	510	1,1	1,5	0,92	1,00	71	80	90
174,20		16,1	410	0,75	1,0	0,92	1,24	71	80	90
208,12		13,5	490	0,75	1,0	0,92	1,04	71	80	
233,85		12,0	404	0,55	0,75	0,92	1,26	71	80	
262,57		10,7	453	0,55	0,75	0,92	1,13	71	80	
306,67		9,1	356	0,37	0,5	0,92	1,19	71	80	90
366,38		7,6	425	0,37	0,5	0,92	1,00	71	80	
411,67		6,8	478	0,37	0,5	0,92	0,89	71	80	
462,24		6,1	537	0,37	0,5	0,92	0,79	71	80	

32,17	1400	43,5	620	3,1	4,1	0,92
38,13		36,7	620	2,6	3,5	0,92
43,14		32,5	620	2,3	3,1	0,92
49,33		28,4	620	2,0	2,7	0,92
57,19		24,5	620	1,7	2,3	0,92
67,45		20,8	620	1,5	2,0	0,92
83,08		16,9	600	1,2	1,5	0,92
98,46		14,2	600	1,0	1,3	0,92
111,41		12,6	600	0,9	1,1	0,92
127,41		11,0	600	0,8	1,0	0,92
147,69		9,5	600	0,6	0,9	0,92
174,2		8,0	600	0,5	0,7	0,92
208,12		6,7	600	0,5	0,6	0,92
233,85		6,0	600	0,4	0,5	0,92
262,57		5,3	600	0,4	0,5	0,92
306,67		4,6	500	0,3	0,3	0,92
366,38		3,8	500	0,2	0,3	0,92
411,67		3,4	500	0,2	0,3	0,92
462,24		3,0	500	0,2	0,2	0,92

32,17	1400	43,5	606	3	4,0	0,92	1,02		90	100	
38,13		36,7	526	2,2	3,0	0,92	1,18		80	90	100
43,14		32,5	596	2,2	3,0	0,92	1,04		80	90	100
49,33		28,4	464	1,5	2,0	0,92	1,34		80	90	
57,19		24,5	538	1,5	2,0	0,92	1,15	71	80	90	
67,45		20,8	635	1,5	2,0	0,92	0,98	71	80	90	
83,08		16,9	574	1,1	1,5	0,92	1,05		90	100	
98,46		14,2	568	0,92	1,2	0,92	1,06		80	90	
111,41		12,6	524	0,75	1,0	0,92	1,14		80	90	
127,41		11,0	600	0,75	1,0	0,92	1,00		80	90	
147,69		9,5	510	0,55	0,75	0,92	1,18	71	80	90	
174,20		8,0	601	0,55	0,75	0,92	1,00	71	80	90	
208,12		6,7	483	0,37	0,5	0,92	1,24	71	80		
233,85		6,0	543	0,37	0,5	0,92	1,10	71	80		
262,57		5,3	610	0,37	0,5	0,92	0,98	71	80		
306,67		4,6	481	0,25	0,33	0,92	1,04	71	80	90	
366,38		3,8	575	0,25	0,33	0,92	0,87	71	80		
411,67		3,4	646	0,25	0,33	0,92	0,77	71	80		
462,24		3,0	725	0,25	0,33	0,92	0,69	71	80		

32,17	900	28,0	682	2,2	2,9	0,92
38,13		23,6	682	1,8	2,4	0,92
43,14		20,9	682	1,6	2,2	0,92
49,33		18,2	682	1,4	1,9	0,92
57,19		15,7	682	1,2	1,6	0,92
67,45		13,3	682	1,0	1,4	0,92
83,08		10,8	660	0,8	1,1	0,92
98,46		9,1	660	0,7	0,9	0,92
111,41		8,1	660	0,6	0,8	0,92
127,41		7,1	660	0,5	0,7	0,92
147,69		6,1	660	0,5	0,6	0,92
174,2		5,2	660	0,4	0,5	0,92
208,12		4,3	660	0,3	0,4	0,92
233,85		3,8	660	0,3	0,4	0,92
262,57		3,4	660	0,3	0,3	0,92
306,67		2,9	550	0,2	0,2	0,92
366,38		2,5	550	0,2	0,2	0,92
411,67		2,2	550	0,1	0,2	0,92
462,24		1,9	550	0,1	0,2	0,92

32,17	900	28,0	471	1,5	2,0	0,92	1,45		90	100	
38,13		23,6	558	1,5	2,0	0,92	1,22		80	90	100
43,14		20,9	632	1,5	2,0	0,92	1,08		80	90	100
49,33		18,2	530	1,1	1,5	0,92	1,29		80	90	
57,19		15,7	614	1,1	1,5	0,92	1,11	71	80	90	
67,45		13,3	494	0,75	1,0	0,92	1,38	71	80	90	
83,08		10,8	608	0,75	1,0	0,92	1,09		90	100	
98,46		9,1	529	0,55	0,75	0,92	1,25		80	90	
111,41		8,1	598	0,55	0,75	0,92	1,10		80	90	
127,41		7,1	460	0,37	0,5	0,92	1,43		80	90	
147,69		6,1	533	0,37	0,5	0,92	1,24	71	80	90	
174,20		5,2	629	0,37	0,5	0,92	1,05	71	80	90	
208,12		4,3	508	0,25	0,33	0,92	1,30	71	80		
233,85		3,8	571	0,25	0,33	0,92	1,16	71	80		
262,57		3,4	641	0,25	0,33	0,92	1,03	71	80		
306,67		2,9	539	0,18	0,25	0,92	1,02	71	80	90	
366,38		2,5	644	0,18	0,25	0,92	0,85	71	80		
411,67		2,2	723	0,18	0,25	0,92	0,76	71	80		
462,24		1,9	812	0,18	0,25	0,92	0,68	71	80		

OT 100

PRESTAZIONI

PERFORMANCES

LEISTUNG

MOT 100

i	n ₁	n ₂	M ₂	KW ₁	HP ₁	R.D.
9.53	2800	293.8	705.5	22.6	30.1	0.96
12.31		227.5	754.0	18.7	24.9	0.96
15.00		186.7	867.0	17.7	23.5	0.96
19.06		146.9	892.5	14.3	19.1	0.96
24.62		113.7	977.5	12.1	16.2	0.96
30.00		93.3	867.0	8.8	11.8	0.96
43.33		64.6	790.5	5.6	7.4	0.96
56.46		49.6	740.0	4.0	5.3	0.96

i	n ₁	n ₂	M ₂	KW ₁	HP ₁	R.D.	fs	P.A.M.
9.53	2800	293.8	343	11	15.0	0.96	2.06	100 132
12.31		227.5	443	11	15.0	0.96	1.70	100 132
15.00		186.7	540	11	15.0	0.96	1.60	100 132
19.06		146.9	687	11	15.0	0.96	1.30	100 132
24.62		113.7	887	11	15.0	0.96	1.10	100 132
30.00		93.3	737	7.5	10.0	0.96	1.18	100 132
43.33		64.6	780	5.5	7.5	0.96	1.01	100 100
56.46		49.6	740	4	5.5	0.96	1.00	100

9.53	1400	146.9	830	13.3	17.7	0.96
12.31		113.7	887	11.0	14.7	0.96
15.00		93.3	1020	10.4	13.8	0.96
19.06		73.4	1050	8.4	11.2	0.96
24.62		56.9	1150	7.1	9.5	0.96
30.00		46.7	1020	5.2	6.9	0.96
43.33		32.3	930	3.3	4.4	0.96
56.46		24.8	880	2.4	3.2	0.96

9.53	1400	146.9	687	11	15.0	0.96	1.21	100 132
12.31		113.7	887	11	15.0	0.96	1.00	100 132
15.00		93.3	904	9.2	12.5	0.96	1.13	100 132
19.06		73.4	936	7.5	10.0	0.96	1.12	100 132
24.62		56.9	1209	7.5	10.0	0.96	0.95	100 132
30.00		46.7	786	4	5.5	0.96	1.30	100 132
43.33		32.3	851	3	4.0	0.96	1.09	100
56.46		24.8	813	2.2	3.0	0.96	1.08	100

9.53	900	94.4	913	9.4	12.5	0.96
12.31		73.1	976	7.8	10.4	0.96
15.00		60.0	1122	7.3	9.8	0.96
19.06		47.2	1155	5.9	7.9	0.96
24.62		36.6	1265	5.0	6.7	0.96
30.00		30.0	1122	3.7	4.9	0.96
43.33		20.8	1023	2.3	3.1	0.96
56.46		15.9	968	1.7	2.2	0.96

9.53	900	94.4	534	5.5	7.5	0.96	1.71	100 132
12.31		73.1	690	5.5	7.5	0.96	1.41	100 132
15.00		60.0	840	5.5	7.5	0.96	1.34	100 132
19.06		47.2	1068	5.5	7.5	0.96	1.08	100 132
24.62		36.6	1003	4	5.5	0.96	1.26	100 132
30.00		30.0	917	3	4.0	0.96	1.22	100 132
43.33		20.8	971	2.2	3.0	0.96	1.05	100
56.46		15.9	863	1.5	2.0	0.96	1.12	100

DIMENSIONI DI INGOMBRO

OVERALL DIMENSIONS

ALLGEMEINE ABMESSUNGEN

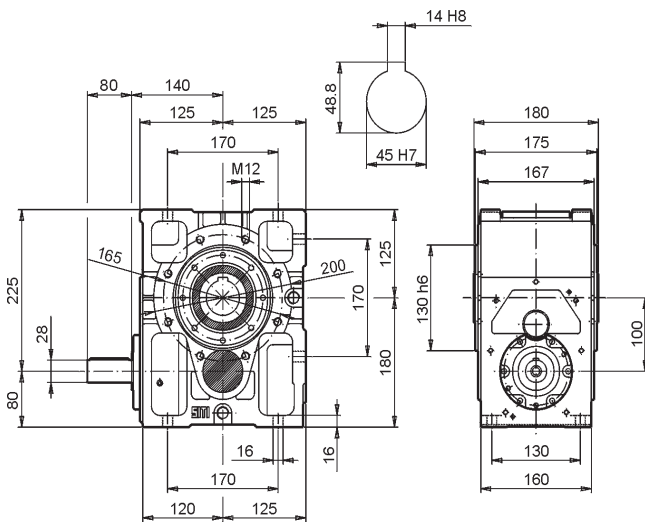

OT 100

= 45

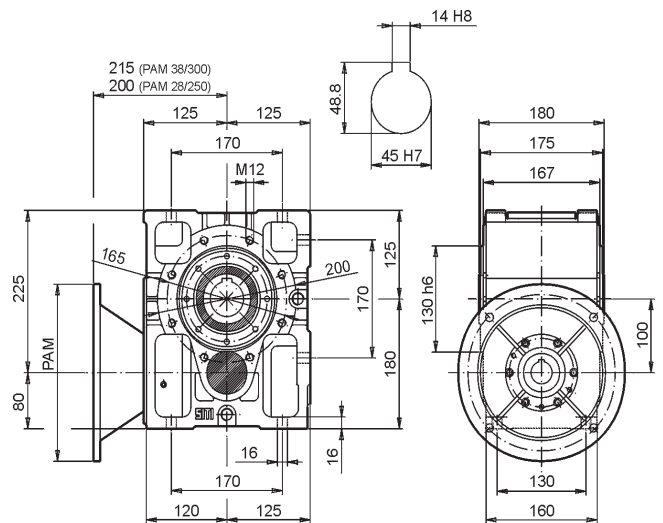

= 49

MOT 100

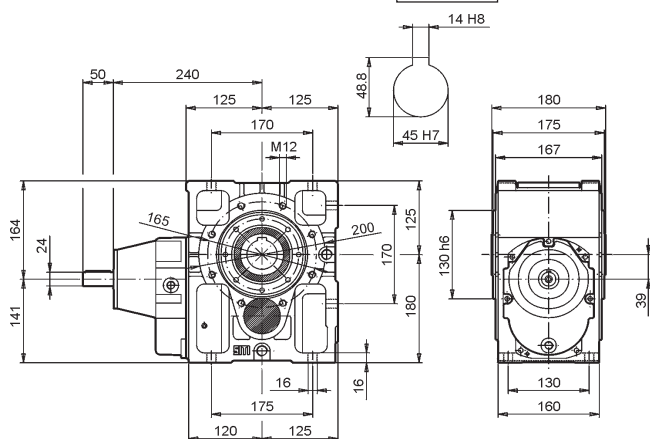

OT 100/3

= 53

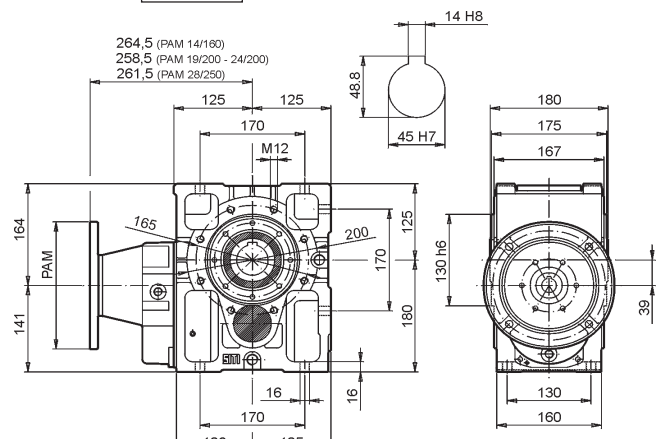

= 55

MOT 100/3

i	n ₁	n ₂	M ₂	KW ₁	HP ₁	R.D.
32,17	2800	87,0	957	9,48	12,6	0,92
38,13		73,4	1148	9,59	12,8	0,92
43,14		64,9	1148	8,48	11,3	0,92
49,33		56,8	1148	7,41	9,9	0,92
57,19		49,0	1037	5,78	7,7	0,92
67,45		41,5	893	4,22	5,6	0,92
83,08		33,7	1020	3,91	5,2	0,92
98,46		28,4	1020	3,30	4,4	0,92
111,41		25,1	1020	2,92	3,9	0,92
127,41		22,0	1020	2,55	3,4	0,92
147,69		19,0	1020	2,20	2,9	0,92
174,20		16,1	1020	1,87	2,5	0,92
208,12		13,5	1020	1,56	2,1	0,92
233,85		12,0	1020	1,39	1,9	0,92
262,57		10,7	1020	1,24	1,7	0,92
306,66		9,1	791	0,82	1,1	0,92
366,38		7,6	791	0,69	0,9	0,92
411,67		6,8	791	0,61	0,8	0,92
462,24		6,1	791	0,55	0,7	0,92

i	n ₁	n ₂	M ₂	KW ₁	HP ₁	R.D.	fs	P.A.M.			
32,17	2800	87,0	555	5,5	7,5	0,92	1,72		90	100	
38,13		73,4	658	5,5	7,5	0,92	1,74	80	90	100	
43,14		64,9	745	5,5	5,5	0,92	1,54	80	90	100	
49,33		56,8	851	5,5	5,5	0,92	1,35	80	90	100	
57,19		49,0	987	5,5	7,5	0,92	1,05	71	80	90	100
67,45		41,5	847	4	5,5	0,92	1,05	71	80	90	100
83,08		33,7	782	3	4,0	0,92	1,30			90	100
98,46		28,4	927	3	4,0	0,92	1,10		80	90	
111,41		25,1	769	2,2	3,0	0,92	1,33		80	90	
127,41		22,0	880	2,2	3,0	0,92	1,16		80	90	
147,69		19,0	1020	2,2	3,0	0,92	1,00	71	80	90	
174,20		16,1	820	1,5	2,0	0,92	1,24	71	80	90	
208,12		13,5	980	1,5	2,0	0,92	1,04	71	80		
233,85		12,0	807	1,1	1,5	0,92	1,26	71	80		
262,57		10,7	906	1,1	1,5	0,92	1,13	71	80		
306,66		9,1	722	0,75	1,0	0,92	1,10	71	80	90	
366,38		7,6	632	0,55	0,75	0,92	1,25	71	80		
411,67		6,8	710	0,55	0,75	0,92	1,11	71	80		
462,24		6,1	798	0,55	0,75	0,92	0,99	71	80		

32,17	1400	43,5	1126	5,58	7,4	0,92
38,13		36,7	1350	5,64	7,5	0,92
43,14		32,5	1350	4,99	6,6	0,92
49,33		28,4	1350	4,36	5,8	0,92
57,19		24,5	1220	3,40	4,5	0,92
67,45		20,8	1050	2,48	3,3	0,92
83,08		16,9	1200	2,30	3,1	0,92
98,46		14,2	1200	1,94	2,6	0,92
111,41		12,6	1200	1,72	2,3	0,92
127,41		11,0	1200	1,50	2,0	0,92
147,69		9,5	1200	1,29	1,7	0,92
174,20		8,0	1200	1,10	1,5	0,92
208,12		6,7	1200	0,92	1,2	0,92
233,85		6,0	1200	0,82	1,1	0,92
262,57		5,3	1200	0,73	1,0	0,92
306,67		4,6	930	0,48	0,6	0,92
366,38		3,8	930	0,40	0,5	0,92
411,67		3,4	930	0,36	0,5	0,92
462,24		3,0	930	0,32	0,4	0,92

32,17	1400	43,5	808	4	5,5	0,92	1,39		90	100	
38,13		36,7	957	4	5,5	0,92	1,41	80	90	100	
43,14		32,5	1083	4	5,5	0,92	1,25	80	90	100	
49,33		28,4	1238	4	5,5	0,92	1,09	80	90	100	
57,19		24,5	1077	3	4,0	0,92	1,13	71	80	90	100
67,45		20,8	931	2,2	3,0	0,92	1,13	71	80	90	100
83,08		16,9	1147	2,2	3,0	0,92	1,05			90	100
98,46		14,2	927	1,5	2,0	0,92	1,29		80	90	
111,41		12,6	1049	1,5	2,0	0,92	1,14		80	90	
127,41		11,0	1199	1,5	2,0	0,92	1,00		80	90	
147,69		9,5	1020	1,1	1,5	0,92	1,18	71	80	90	
174,20		8,0	1203	1,1	1,5	0,92	1,00	71	80	90	
208,12		6,7	980	0,75	1,0	0,92	1,23	71	80		
233,85		6,0	1101	0,75	1,0	0,92	1,09	71	80		
262,57		5,3	1236	0,75	1,0	0,92	0,97	71	80		
306,67		4,6	712	0,37	0,5	0,92	1,31	71	80	90	
366,38		3,8	851	0,37	0,5	0,92	1,09	71	80		
411,67		3,4	956	0,37	0,5	0,92	0,97	71	80		
462,24		3,0	725	0,25	0,33	0,92	1,28	71	80		

32,17	900	28,0	1239	3,94	5,3	0,92
38,13		23,6	1485	3,99	5,3	0,92
43,14		20,9	1485	3,53	4,7	0,92
49,33		18,2	1485	3,08	4,1	0,92
57,19		15,7	1342	2,40	3,2	0,92
67,45		13,3	1155	1,75	2,3	0,92
83,08		10,8	1320	1,63	2,2	0,92
98,46		9,1	1320	1,37	1,8	0,92
111,41		8,1	1320	1,21	1,6	0,92
127,41		7,1	1320	1,06	1,4	0,92
147,69		6,1	1320	0,92	1,2	0,92
174,20		5,2	1320	0,78	1,0	0,92
208,12		4,3	1320	0,65	0,9	0,92
233,85		3,8	1320	0,58	0,8	0,92
262,57		3,4	1320	0,51	0,7	0,92
306,67		2,9	1023	0,34	0,5	0,92
366,38		2,5	1023	0,29	0,4	0,92
411,67		2,2	1023	0,25	0,3	0,92
462,24		1,9	1023	0,23	0,3	0,92

32,17	900	28,0	691	2,2	3,0	0,92	1,79		90	100	
38,13		23,6	819	2,2	3,0	0,92	1,81	80	90	100	
43,14		20,9	927	2,2	3,0	0,92	1,60	80	90	100	
49,33		18,2	1059	2,2	3,0	0,92	1,40	80	90	100	
57,19		15,7	1228	2,2	3,0	0,92	1,09	71	80	90	100
67,45		13,3	988	1,5	2,0	0,92	1,17	71	80	90	100
83,08		10,8	1217	1,5	2,0	0,92	1,09			90	100
98,46		9,1	1057	1,1	1,5	0,92	1,25		80	90	
111,41		8,1	1196	1,1	1,5	0,92	1,10		80	90	
127,41		7,1	1368	1,1	1,5	0,92	0,96		80	90	
147,69		6,1	1081	0,75	1,0	0,92	1,22	71	80	90	
174,20		5,2	1275	0,75	1,0	0,92	1,03	71	80	90	
208,12		4,3	1117	0,55	0,75	0,92	1,18	71	80		
233,85		3,8	1256	0,55	0,75	0,92	1,05	71	80		
262,57		3,4	948	0,37	0,5	0,92	1,39	71	80		
306,67		2,9	748	0,25	0,33	0,92	1,37	71	80	90	
366,38		2,5	894	0,25	0,33	0,92	1,14	71	80		
411,67		2,2	1005	0,25	0,33	0,92	1,02	71	80		
462,24		1,9	812	0,18	0,25	0,92	1,26	71	80		

OT 125

PRESTAZIONI

PERFORMANCES

LEISTUNG

MOT 125

i	n ₁	n ₂	M ₂	KW ₁	HP ₁	R.D.
10.0	2800	280.0	1275	38.9	51.9	0.96
12.9		217.4	1277	30.3	40.4	0.96
15.7		178.5	1573	30.6	40.8	0.96
17.3		161.5	1737	30.6	40.8	0.96
22.3		125.4	1865	25.5	34.0	0.96
27.2		103.0	1615	18.1	24.2	0.96
34.0		82.3	1615	14.5	19.3	0.96
46.9		59.8	1445	9.4	12.6	0.96

i	n ₁	n ₂	M ₂	KW ₁	HP ₁	R.D.	fs	P.A.M.
10.0	2800	280.0	606	18.5	25	0.96	2.10	132 160
12.9		217.4	780	18.5	25	0.96	1.64	132 160
15.7		178.5	950	18.5	25	0.96	1.66	132 160
17.3		161.5	1050	18.5	25	0.96	1.65	132 160
22.3		125.4	1353	18.5	25	0.96	1.38	132 160
27.2		103.0	1647	18.5	25	0.96	0.98	132 160
34.0		82.3	1226	11	15	0.96	1.32	132
46.9		59.8	1412	9.2	12.5	0.96	1.02	132

10.0	1400	140.0	1500	22.9	30.5	0.96
12.9		108.7	1501	17.8	23.7	0.96
15.7		89.3	1850	18.0	24.0	0.96
17.3		80.8	2043	18.0	24.0	0.96
22.3		62.7	2194	15.0	20.0	0.96
27.2		51.5	1900	10.7	14.2	0.96
34.0		41.1	1901	8.5	11.4	0.96
46.9		29.9	1700	5.5	7.4	0.96

10.0	1400	140.0	982	15	20	0.96	1.53	132 160
12.9		108.7	1265	15	20	0.96	1.19	132 160
15.7		89.3	1541	15	20	0.96	1.20	132 160
17.3		80.8	1703	15	20	0.96	1.20	132 160
22.3		62.7	2194	15	20	0.96	1.00	132 160
27.2		51.5	1958	11	15	0.96	0.97	132 160
34.0		41.1	1672	7.5	10	0.96	1.14	132
46.9		29.9	1688	5.5	7.5	0.96	1.01	132

10.0	900	90.0	1650	16.2	21.6	0.96
12.9		69.9	1652	12.6	16.8	0.96
15.7		57.4	2035	12.7	17.0	0.96
17.3		51.9	2247	12.7	17.0	0.96
22.3		40.3	2413	10.6	14.1	0.96
27.2		33.1	2090	7.5	10.1	0.96
34.0		26.4	2090	6.0	8.0	0.96
46.9		19.2	1870	3.9	5.2	0.96

10.0	900	90.0	1121	11	15	0.96	1.47	132 160
12.9		69.9	1443	11	15	0.96	1.14	132 160
15.7		57.4	1757	11	15	0.96	1.16	132 160
17.3		51.9	1942	11	15	0.96	1.16	132 160
22.3		40.3	1706	7.5	10	0.96	1.41	132 160
27.2		33.1	2077	7.5	10	0.96	1.01	132 160
34.0		26.4	1907	5.5	7.50	0.96	1.10	132
46.9		19.2	1432	3	4.00	0.96	1.31	132

DIMENSIONI DI INGOMBRO

OVERALL DIMENSIONS

ALLGEMEINE ABMESSUNGEN

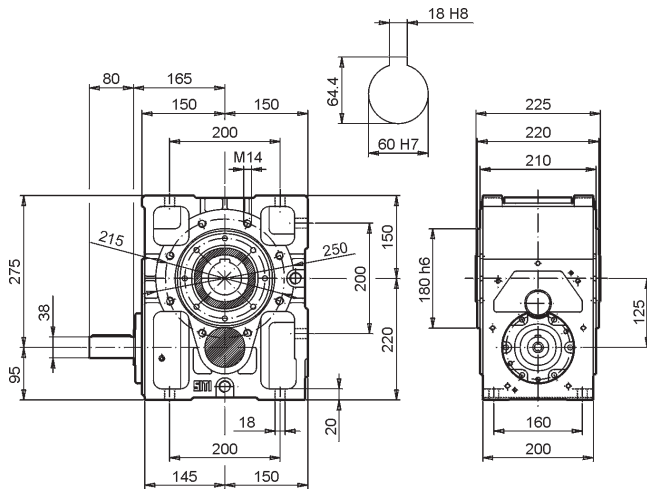

OT 125

= 82

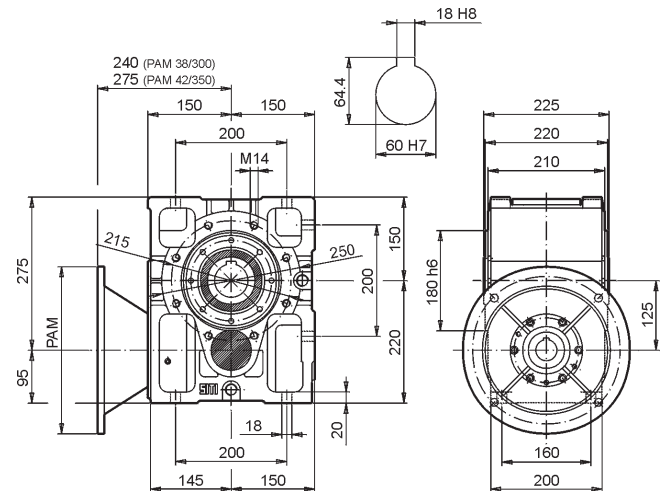

= 87

MOT 125

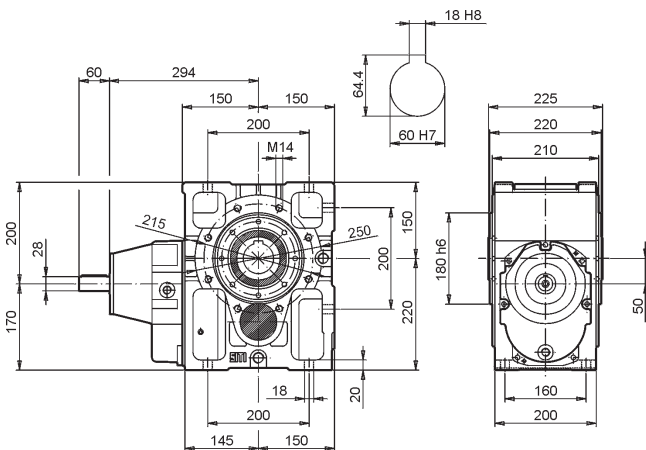

OT 125/3

= 95

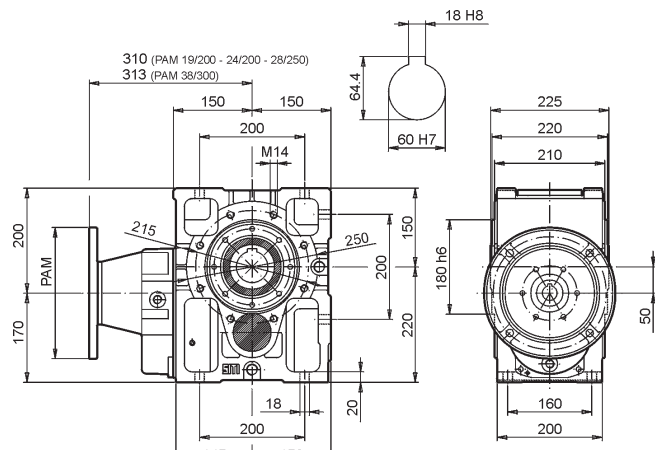

= 97

MOT 125/3

i	n ₁	n ₂	M ₂	KW ₁	HP ₁	R.D.
25,24	2800	110,9	2125	26,8	35,8	0,92
28,95		96,7	2125	23,4	31,2	0,92
32,00		87,5	2126	21,2	28,2	0,92
38,43		72,9	2126	17,6	23,5	0,92
43,75		64,0	2125	15,5	20,6	0,92
50,18		55,8	2169	13,8	18,4	0,92
58,12		48,2	2167	11,9	15,8	0,92
68,18		41,1	2166	10,1	13,5	0,92
81,33		34,4	2168	8,5	11,3	0,92
89,56		31,3	2168	7,7	10,3	0,92
110,93		25,2	2213	6,4	8,5	0,92
125,19		22,4	2211	5,6	7,5	0,92
144,97		19,3	2213	4,9	6,5	0,92
161,20		17,4	2170	4,3	5,7	0,92
181,04		15,5	1697	3,0	4,0	0,92
233,26		12,0	1879	2,6	3,4	0,92
283,90		9,9	1658	1,9	2,5	0,92
299,90		9,3	1530	1,6	2,2	0,92
346,25		8,1	1641	1,5	2,0	0,92
385,02		7,3	1636	1,4	1,8	0,92
432,40	6,5	1625	1,2	1,6	0,92	
489,43	5,7	1441	0,9	1,3	0,92	

i	n ₁	n ₂	M ₂	KW ₁	HP ₁	R.D.	fs	P.A.M.				
25,24	2800	110,9	871	11	15,0	0,92	2,44			100	112	132
28,95		96,7	999	11	15,0	0,92	2,13		90	100	112	132
32,00		87,5	1105	11	15,0	0,92	1,92			100	112	132
38,43		72,9	1326	11	15,0	0,92	1,60			100	112	132
43,75		64,0	1510	11	15,0	0,92	1,41			100	112	132
50,18		55,8	1732	11	15,0	0,92	1,25		90	100	112	132
58,12		48,2	2006	11	15,0	0,92	1,08		90	100	112	132
68,18		41,1	1968	9,2	12,5	0,92	1,10		90	100	112	132
81,33		34,4	1914	7,5	10,0	0,92	1,13		90	100	112	132
89,56		31,3	2108	7,5	10,0	0,92	1,03		90	100	112	
110,93		25,2	1914	5,5	7,5	0,92	1,16		90	100		
125,19		22,4	2161	5,5	7,5	0,92	1,02	80	90	100		
144,97		19,3	1820	4	5,5	0,92	1,22	80	90	100		
161,20		17,4	2023	4	5,5	0,92	1,07	80	90	100		
181,04		15,5	1704	3	4,0	0,92	1,00	80	90	100		
233,26		12,0	1610	2,2	3,0	0,92	1,17	80	90	100		
283,90		9,9	1336	1,5	2,0	0,92	1,24	80	90	100		
299,90		9,3	1412	1,5	2,0	0,92	1,08	80	90	100		
346,25		8,1	1630	1,5	2,0	0,92	1,01	80	90	100		
385,02		7,3	1329	1,1	1,5	0,92	1,23	80	90	100		
432,40	6,5	1492	1,1	1,5	0,92	1,09	80	90	100			
489,43	5,7	1152	0,75	1,0	0,92	1,25	80	90	100			

i	n ₁	n ₂	M ₂	KW ₁	HP ₁	R.D.
25,24	1400	55,5	2447	15,5	20,6	0,92
28,95		48,4	2447	13,5	18,0	0,92
32,00		43,8	2448	12,2	16,3	0,92
38,43		36,4	2448	10,2	13,5	0,92
43,75		32,0	2446	8,9	11,9	0,92
50,18		27,9	2497	7,9	10,6	0,92
58,12		24,1	2495	6,8	9,1	0,92
68,18		20,5	2495	5,8	7,8	0,92
81,33		17,2	2496	4,9	6,5	0,92
89,56		15,6	2496	4,4	5,9	0,92
110,93		12,6	2548	3,7	4,9	0,92
125,19		11,2	2546	3,2	4,3	0,92
144,97		9,7	2547	2,8	3,7	0,92
161,20		8,7	2499	2,5	3,3	0,92
181,04		7,7	1954	1,7	2,3	0,92
233,26		6,0	2210	1,5	2,0	0,92
283,90		4,9	1950	1,1	1,5	0,92
299,90		4,7	1800	0,9	1,2	0,92
346,25		4,0	1890	0,9	1,2	0,92
385,02		3,6	1885	0,8	1,0	0,92
432,40	3,2	1872	0,7	0,9	0,92	
489,43	2,9	1659	0,5	0,7	0,92	

i	n ₁	n ₂	M ₂	KW ₁	HP ₁	R.D.	fs	P.A.M.				
25,24	1400	55,5	1742	11	15,0	0,92	1,40			100	112	132
28,95		48,4	1999	11	15,0	0,92	1,22		90	100	112	132
32,00		43,8	2209	11	15,0	0,92	1,11			100	112	132
38,43		36,4	2219	9,2	12,5	0,92	1,10			100	112	132
43,75		32,0	2526	9,2	12,5	0,92	0,97			100	112	132
50,18		27,9	2362	7,5	10,0	0,92	1,06		90	100	112	132
58,12		24,1	2006	5,5	7,5	0,92	1,24		90	100	112	132
68,18		20,5	2353	5,5	7,5	0,92	1,06		90	100	112	132
81,33		17,2	2042	4	5,5	0,92	1,22		90	100	112	132
89,56		15,6	2248	4	5,5	0,92	1,11		90	100	112	
110,93		12,6	2088	3	4,0	0,92	1,22		90	100		
125,19		11,2	2357	3	4,0	0,92	1,08	80	90	100		
144,97		9,7	2002	2,2	3,0	0,92	1,27	80	90	100		
161,20		8,7	2226	2,2	3,0	0,92	1,12	80	90	100		
181,04		7,7	1704	1,5	2,0	0,92	1,15	80	90	100		
233,26		6,0	2196	1,50	2,0	0,92	1,00	80	90	100		
283,90		4,9	1960	1,10	1,5	0,92	1,00	80	90	100		
299,90		4,7	2070	1,10	1,5	0,92	0,84	80	90	100		
346,25		4,0	1630	0,75	1,0	0,92	1,16	80	90	100		
385,02		3,6	1812	0,75	1,0	0,92	1,04	80	90	100		
432,40	3,2	1492	0,55	0,75	0,92	1,25	80	90	100			
489,43	2,9	1689	0,55	0,75	0,92	0,98	80	90	100			

i	n ₁	n ₂	M ₂	KW ₁	HP ₁	R.D.
25,24	900	35,7	2750	11,2	14,9	0,92
28,95		31,1	2750	9,7	13,0	0,92
32,00		28,1	2751	8,8	11,7	0,92
38,43		23,4	2751	7,3	9,8	0,92
43,75		20,6	2750	6,4	8,6	0,92
50,18		17,9	2807	5,7	7,6	0,92
58,12		15,5	2804	4,9	6,6	0,92
68,18		13,2	2803	4,2	5,6	0,92
81,33		11,1	2805	3,5	4,7	0,92
89,56		10,0	2805	3,2	4,3	0,92
110,93		8,1	2863	2,6	3,5	0,92
125,19		7,2	2861	2,3	3,1	0,92
144,97		6,2	2863	2,0	2,7	0,92
161,20		5,6	2808	1,8	2,4	0,92
181,04		5,0	2197	1,2	1,7	0,92
233,07		3,9	2431	1,1	1,4	0,92
283,76		3,2	2145	0,8	1,0	0,92
299,90		3,0	1980	0,7	0,9	0,92
346,25		2,6	2124	0,6	0,8	0,92
385,02		2,3	2118	0,6	0,8	0,92
432,40	2,1	2103	0,5	0,7	0,92	
489,43	1,8	1865	0,4	0,5	0,92	

i	n ₁	n ₂	M ₂	KW ₁	HP ₁	R.D.	fs	P.A.M.				
25,24	900	35,7	1355	5,5	7,5	0,92	2,03			100	112	132
28,95		31,1	1554	5,5	7,5	0,92	1,77		90	100	112	132
32,00		28,1	1718	5,5	7,5	0,92	1,60			100	112	132
38,43		23,4	2063	5,5	7,5	0,92	1,33			100	112	132
43,75		20,6	2349	5,5	7,5	0,92	1,17			100	112	132
50,18		17,9	2694	5,5	7,5	0,92	1,04		90	100	112	132
58,12		15,5	2270	4	5,5	0,92	1,24		90	100	112	132
68,18		13,2	2662	4	5,5	0,92	1,05		90	100	112	132
81,33		11,1	2382	3	4,0	0,92	1,18		90	100	112	132
89,56		10,0	1923	2,2	3,0	0,92	1,46		90	100	112	
110,93		8,1	2382	2,2	3,0	0,92	1,20		90	100		
125,19		7,2	2689	2,2	3,0	0,92	1,06	80	90	100		
144,97		6,2	2123	1,5	2,0	0,92	1,35	80	90	100		
161,20		5,6	2361	1,5	2,0	0,92	1,19	80	90	100		
181,04		5,0	1944	1,1	1,5	0,92	1,13	80	90	100		
233,07		3,9	2503	1,1	1,5	0,92	0,97	80	90	100		
283,76		3,2	2078	0,75	1,0	0,92	1,03	80	90	100		
299,90		3,0	1610	0,55	0,75	0,92	1,23	80	90	100		
346,25		2,6	1859	0,55	0,75	0,92	1,14	80	90	100		
385,02		2,3	2067	0,55	0,75	0,92	1,02	80	90	100		
432,40	2,1	2322	0,55	0,75	0,92	0,91	80	90	100			
489,43	1,8	2628	0,55	0,75	0,92	0,71	80	90	100			

OT 160

PRESTAZIONI

PERFORMANCES

LEISTUNG

MOT 160

i	n ₁	n ₂	M ₂	KW ₁	HP ₁	R.D.
9.53	2800	293.7	2465	79.0	105.3	0.96
12.31		227.5	2805	69.6	92.8	0.96
15.00		186.7	3230	65.8	87.7	0.96
19.06		146.9	3230	51.8	69.0	0.96
24.62		113.8	3400	42.2	56.2	0.96
27.57		101.6	1700	18.8	25.1	0.96
30.00		93.3	3400	34.6	46.2	0.96
35.56		78.8	2210	19.0	25.3	0.96
38.33		73.0	3315	26.4	35.2	0.96
43.33		64.6	3060	21.6	28.8	0.96
55.37		50.6	3315	18.3	24.4	0.96

9.53	1400	146.9	2903	46.5	62.0	0.96
12.31		113.7	3297	40.9	54.5	0.96
15.00		93.3	3801	38.7	51.6	0.96
19.06		73.5	3794	30.4	40.5	0.96
24.62		56.9	3998	24.8	33.1	0.96
27.57		50.8	2004	11.1	14.8	0.96
30.00		46.7	4008	20.4	27.2	0.96
35.56		39.4	2608	11.2	14.9	0.96
38.33		36.5	3891	15.5	20.7	0.96
43.33		32.3	3604	12.7	16.9	0.96
55.37		25.3	3916	10.8	14.4	0.96

9.53	900	94.4	3190	32.8	43.8	0.96
12.31		73.1	3630	29.0	38.6	0.96
15.00		60.0	4180	27.4	36.5	0.96
19.06		47.2	4180	21.5	28.7	0.96
24.62		36.6	4400	17.5	23.4	0.96
27.57		32.6	2200	7.8	10.4	0.96
30.00		30.0	4400	14.4	19.2	0.96
35.56		25.3	2860	7.9	10.5	0.96
38.33		23.5	4290	11.0	14.6	0.96
43.33		20.8	3960	9.0	12.0	0.96
55.37		16.3	4290	7.6	10.1	0.96

i	n ₁	n ₂	M ₂	KW ₁	HP ₁	R.D.	fs	P.A.M.
9.53	2800	293.7	687	22	30	0.96	3.59	160 180
12.31		227.5	887	22	30	0.96	3.16	160 180
15.00		186.7	1081	22	30	0.96	2.99	160 180
19.06		146.9	1373	22	30	0.96	2.35	160 180
24.62		113.8	1773	22	30	0.96	1.92	160 180
27.57		101.6	993	11	15	0.96	1.71	160 180
30.00		93.3	2161	22	30	0.96	1.57	160 180
35.56		78.8	1281	11	15	0.96	1.73	160
38.33		73.0	2761	22	30	0.96	1.20	160 180
43.33		64.6	1561	11	15	0.96	1.96	160
55.37		50.6	1994	11	15	0.96	1.66	160

9.53	1400	146.9	1373	22	30	0.96	2.11	160 180
12.31		113.7	1773	22	30	0.96	1.86	160 180
15.00		93.3	2161	22	30	0.96	1.76	160 180
19.06		73.5	2746	22	30	0.96	1.38	160 180
24.62		56.9	3546	22	30	0.96	1.13	160 180
27.57		50.8	1986	11	15	0.96	1.01	160 180
30.00		46.7	3634	18.5	25	0.96	1.10	160 180
35.56		39.4	2561	11	15	0.96	1.02	160
38.33		36.5	3765	15	20	0.96	1.03	160 180
43.33		32.3	3121	11	15	0.96	1.15	160
55.37		25.3	3988	11	15	0.96	0.98	160

9.53	900	94.4	1457	15	20	0.96	2.19	160 180
12.31		73.1	1881	15	20	0.96	1.93	160 180
15.00		60.0	2292	15	20	0.96	1.82	160 180
19.06		47.2	2912	15	20	0.96	1.44	160 180
24.62		36.6	3761	15	20	0.96	1.17	160 180
27.57		32.6	1545	5.5	7.5	0.96	1.42	160 180
30.00		30.0	4584	15	20	0.96	0.96	160 180
35.56		25.3	1992	5.5	7.5	0.96	1.44	160
38.33		23.5	4295	11	15	0.96	1.00	160 180
43.33		20.8	2428	5.5	7.5	0.96	1.63	160
55.37		16.3	3102	5.5	7.5	0.96	1.38	160

DIMENSIONI DI INGOMBRO

OVERALL DIMENSIONS

ALLGEMEINE ABMESSUNGEN

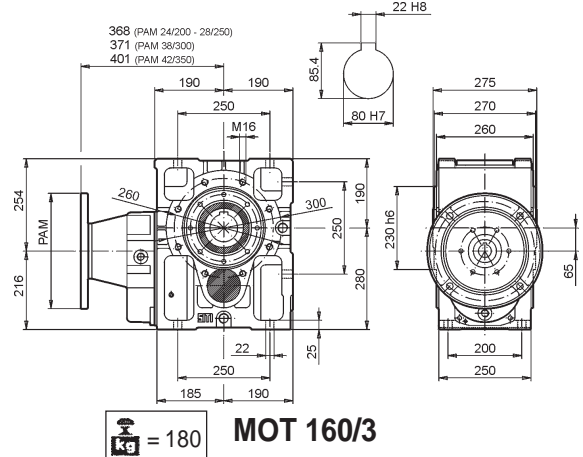
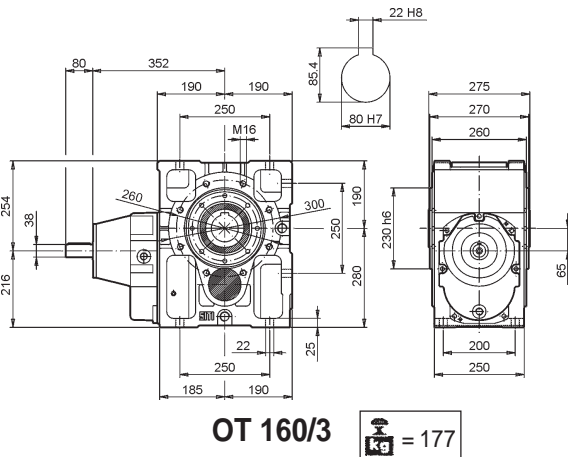
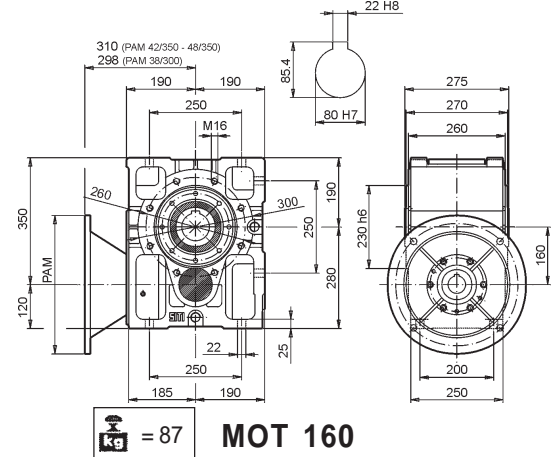
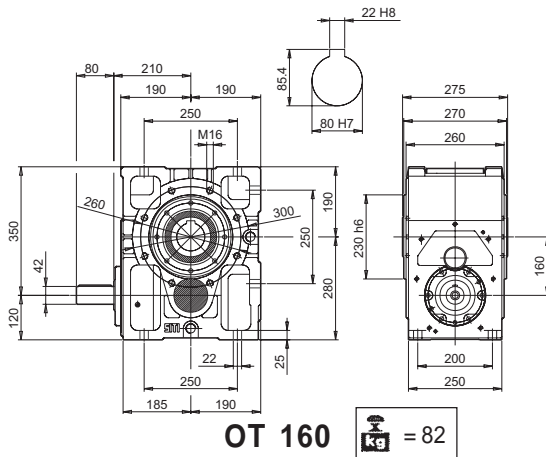

i	n ₁	n ₂	M ₂	KW1	HP1	R.D.
41,49	2800	67,5	3655	28,1	37	0,92
47,69		58,7	3655	24,4	33	0,92
55,17		50,8	3655	21,1	28	0,92
64,38		43,5	3655	18,1	24	0,92
75,99		36,8	3655	15,3	20	0,92
85,57		32,7	3655	13,6	18	0,92
97,17		28,8	3655	12,0	16	0,92
111,49		25,1	3655	10,4	14	0,92
129,64		21,6	3740	9,2	12	0,92
153,37		18,3	3740	7,8	10	0,92
168,21		16,6	3740	7,1	9	0,92
206,77		13,5	3740	5,8	8	0,92
232,48		12,0	3740	5,1	7	0,92
266,29		10,5	3740	4,5	6	0,92
283,33		9,9	3485	3,9	5	0,92
324,55		8,6	3485	3,4	5	0,92
362,04		7,7	3315	2,9	4	0,92
414,70		6,8	3315	2,5	3	0,92
522,94		5,4	3315	2,0	3	0,92
599,01		4,7	3315	1,8	2	0,92

i	n ₁	n ₂	M ₂	KW ₁	HP ₁	R.D.	fs	P.A.M.				
41,49	2800	67,5	2409	18,5	25,0	0,92	1,52				132	160
47,69		58,7	2768	18,5	25,0	0,92	1,32				132	160
55,17		50,8	3203	18,5	25,0	0,92	1,14				132	160
64,38		43,5	2222	11,0	15,0	0,92	1,64			112	132	160
75,99		36,8	2623	11,0	15,0	0,92	1,39		100	112	132	160
85,57		32,7	2954	11,0	15,0	0,92	1,24		100	112	132	160
97,17		28,8	3354	11,0	15,0	0,92	1,09		100	112	132	
111,49		25,1	3219	9,2	12,5	0,92	1,14		100	112	132	
129,64		21,6	3051	7,5	10,0	0,92	1,23		100	112	132	
153,37		18,3	3609	7,5	10,0	0,92	1,04		100	112	132	
168,21		16,6	2903	5,5	7,5	0,92	1,29	90	100	112		
206,77		13,5	3568	5,5	7,5	0,92	1,05	90	100	112		
232,48		12,0	2918	4,0	5,5	0,92	1,28	90	100	112		
266,29		10,5	3342	4,0	5,5	0,92	1,12	90	100	112		
283,33		9,9	3556	4,0	5,5	0,92	0,98	90	100	112		
324,55		8,6	3055	3,0	4,0	0,92	1,14	90	100	112		
362,04		7,7	3408	3,0	4,0	0,92	0,97	90	100	112		
414,70		6,8	2863	2,2	3,0	0,92	1,16	90	100	112		
522,94		5,4	2461	1,5	2,0	0,92	1,35	90	100	112		
599,01		4,7	2819	1,5	2,0	0,92	1,18	90	100	112		

i	n ₁	n ₂	M ₂	KW1	HP1	R.D.
41,49	1400	33,7	4300	16,5	22,0	0,92
47,69		29,4	4300	14,4	19,2	0,92
55,17		25,4	4300	12,4	16,6	0,92
64,38		21,7	4300	10,6	14,2	0,92
75,99		18,4	4300	9,0	12,0	0,92
85,57		16,4	4300	8,0	10,7	0,92
97,17		14,4	4300	7,1	9,4	0,92
111,49		12,6	4300	6,1	8,2	0,92
129,64		10,8	4400	5,4	7,2	0,92
153,37		9,1	4400	4,6	6,1	0,92
168,21		8,3	4400	4,2	5,6	0,92
206,77		6,8	4400	3,4	4,5	0,92
232,48		6,0	4400	3,0	4,0	0,92
266,29		5,3	4400	2,6	3,5	0,92
283,33		4,9	4100	2,3	3,1	0,92
324,55		4,3	4100	2,0	2,7	0,92
362,04		3,9	3900	1,7	2,3	0,92
414,70		3,4	3900	1,5	2,0	0,92
522,94		2,7	3900	1,2	1,6	0,92
599,01		2,3	3900	1,0	1,4	0,92

i	n ₁	n ₂	M ₂	KW ₁	HP ₁	R.D.	fs	P.A.M.				
41,49	1400	33,7	3906	15,0	20,0	0,92	1,10				132	160
47,69		29,4	3292	11,0	15,0	0,92	1,31				132	160
55,17		25,4	3809	11,0	15,0	0,92	1,13				132	160
64,38		21,7	3717	9,2	12,5	0,92	1,16			112	132	160
75,99		18,4	3577	7,5	10,0	0,92	1,20		100	112	132	160
85,57		16,4	4028	7,5	10,0	0,92	1,07		100	112	132	160
97,17		14,4	3354	5,5	7,5	0,92	1,28		100	112	132	
111,49		12,6	3848	5,5	7,5	0,92	1,12		100	112	132	
129,64		10,8	3254	4,0	5,5	0,92	1,35		100	112	132	
153,37		9,1	3850	4,0	5,5	0,92	1,14		100	112	132	
168,21		8,3	4223	4,0	5,5	0,92	1,04	90	100	112		
206,77		6,8	3893	3,0	4,0	0,92	1,13	90	100	112		
232,48		6,0	4377	3,0	4,0	0,92	1,01	90	100	112		
266,29		5,3	3677	2,2	3,0	0,92	1,20	90	100	112		
283,33		4,9	3912	2,2	3,0	0,92	1,05	90	100	112		
324,55		4,3	3055	1,5	2,0	0,92	1,34	90	100	112		
362,04		3,9	3408	1,5	2,0	0,92	1,14	90	100	112		
414,70		3,4	2863	1,1	1,5	0,92	1,36	90	100	112		
522,94		2,7	3610	1,1	1,5	0,92	1,08	90	100	112		
599,01		2,3	4135	1,1	1,5	0,92	0,94	90	100	112		

i	n ₁	n ₂	M ₂	KW1	HP1	R.D.
41,49	900	21,7	4730	11,7	15,6	0,92
47,69		18,9	4730	10,2	13,5	0,92
55,17		16,3	4730	8,8	11,7	0,92
64,38		14,0	4730	7,5	10,0	0,92
75,99		11,8	4730	6,4	8,5	0,92
85,57		10,5	4730	5,7	7,5	0,92
97,17		9,3	4730	5,0	6,6	0,92
111,49		8,1	4730	4,3	5,8	0,92
129,64		6,9	4840	3,8	5,1	0,92
153,37		5,9	4840	3,2	4,3	0,92
168,21		5,4	4840	2,9	3,9	0,92
206,77		4,4	4840	2,4	3,2	0,92
232,48		3,9	4840	2,1	2,8	0,92
266,29		3,4	4840	1,9	2,5	0,92
283,33		3,2	4510	1,6	2,2	0,92
324,55		2,8	4510	1,4	1,9	0,92
362,04		2,5	4290	1,2	1,6	0,92
414,70		2,2	4290	1,1	1,4	0,92
522,94		1,7	4290	0,8	1,1	0,92
599,01		1,5	4290	0,7	1,0	0,92

i	n ₁	n ₂	M ₂	KW ₁	HP ₁	R.D.	fs	P.A.M.				
41,49	900	21,7	4455	11,0	15,0	0,92	1,06				132	160
47,69		18,9	3492	7,5	10,0	0,92	1,35				132	160
55,17		16,3	4039	7,5	10,0	0,92	1,17				132	160
64,38		14,0	3457	5,5	7,5	0,92	1,37			112	132	160
75,99		11,8	4080	5,5	7,5	0,92	1,16		100	112	132	160
85,57		10,5	4594	5,5	7,5	0,92	1,03		100	112	132	160
97,17		9,3	3794	4,0	5,5	0,92	1,25		100	112	132	
111,49		8,1	4354	4,0	5,5	0,92	1,09		100	112	132	
129,64		6,9	2784	2,2	3,0	0,92	1,74		100	112	132	
153,37		5,9	3294	2,2	3,0	0,92	1,47		100	112	132	
168,21		5,4	3613	2,2	3,0	0,92	1,34	90	100	112		
206,77		4,4	4441	2,2	3,0	0,92	1,09	90	100	112		
232,48		3,9	4993	2,2	3,0	0,92	0,97	90	100	112		
266,29		3,4	3899	1,5	2,0	0,92	1,24	90	100	112		
283,33		3,2	4149	1,5	2,0	0,92	1,09	90	100	112		
324,55		2,8	3485	1,1	1,5	0,92	1,29	90	100	112		
362,04		2,5	3888	1,1	1,5	0,92	1,10	90	100	112		
414,70		2,2	4453	1,1	1,5	0,92	0,96	90	100	112		
522,94		1,7	3829	0,75	1,0	0,92	1,12	90	100	112		
599,01		1,5	4386	0,75	1,0	0,92	0,98	90	100	112		

CARICHI RADIALI DELLE GRANDEZZE:
80 - 100 - 125 - 160

SIZE OVERHUNG LOADS:
80 - 100 - 125 - 160

RADIALE BELASTUNGEN DER
GRÖSSEN:
80 - 100 - 125 - 160

ALBERO VELOCE/INPUT SHAFT/EINGANGSWELLE		
1400 min ⁻¹	OT 80	OT 80/3
		800

ALBERO LENTO/OUTPUT SHAFT/ABTRIEBSWELLE							
OT 80 - OT 80/3							
min ⁻¹	0°	30°	60°	90°	120°	150°	180°
20	8296	8576	9307	10429	11718	12726	13123
40	6424	6715	7404	8553	9875	10964	11370
60	4942	5149	5774	6814	8010	8997	9413
80	4486	4702	5350	6431	7675	8755	9133
100	4053	4270	4862	5940	7185	8251	8300
120	3727	3891	4538	5567	6864	7944	8376
140	3026	3159	3685	4520	5573	6450	6801
160	4052	4230	4934	6052	7462	8636	9106

ALBERO VELOCE/INPUT SHAFT/EINGANGSWELLE		
1400 min ⁻¹	OT 100	OT 100/3
		1200

ALBERO LENTO/OUTPUT SHAFT/ABTRIEBSWELLE							
OT 100 - OT 100/3							
min ⁻¹	0°	30°	60°	90°	120°	150°	180°
20	13186	13632	14793	16577	18625	20227	20859
40	9972	10422	11491	13274	15327	17017	17646
60	6858	7146	8013	9456	11117	12486	13064
80	6805	7134	8116	9758	11644	13283	13855
100	6684	7041	8019	9795	11848	13607	14347
120	6147	6417	7485	9180	11319	13100	13813
140	5704	5945	6945	8518	10502	12155	12817
160	5346	5580	6509	7984	9844	11393	12013

ALBERO VELOCE/INPUT SHAFT/EINGANGSWELLE		
1400 min ⁻¹	OT 125	OT 125/3
		1900

ALBERO LENTO/OUTPUT SHAFT/ABTRIEBSWELLE							
OT 125 - OT 125/3							
min ⁻¹	0°	30°	60°	90°	120°	150°	180°
20	15823	16358	17752	19892	22350	24273	25031
40	12393	12953	14281	16498	19050	21150	21934
60	9556	9957	11165	13176	15490	17397	18202
80	9510	9970	11344	13637	16273	18563	19364
100	9548	10059	11456	13993	16926	19439	20496
120	8782	9167	10693	13115	16170	18715	19733
140	8148	8505	9921	12168	15003	17364	18309
160	7637	7972	8299	11405	14063	16275	17161

ALBERO VELOCE/INPUT SHAFT/EINGANGSWELLE		
1400 min ⁻¹	OT 160	OT 160/3
		2800

ALBERO LENTO/OUTPUT SHAFT/ABTRIEBSWELLE							
OT 160 - OT 160/3							
min ⁻¹	0°	30°	60°	90°	120°	150°	180°
20	24488	25316	27473	30785	34589	37565	38739
40	16891	17654	19464	22485	25962	28825	29892
60	15552	16205	18171	21443	25209	28314	29624
80	12982	13610	15484	18460	22214	25340	26432
100	12549	13220	15056	18391	22246	25548	26938
120	11541	12047	14053	17236	21252	24596	25935
140	11640	12150	14173	17383	21434	24806	26156
160	10910	11388	13284	16293	20089	23251	24516

Rotazione oraria
Clockwise rotation
Uhrzeigersinn

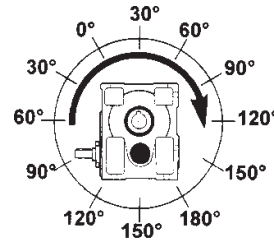

Rotazione antioraria
Anticlockwise rotation
Gegenuhzeigersinn

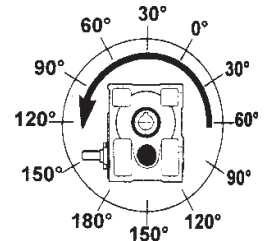

PRESTAZIONI
PERFORMANCES
LEISTUNG

PL..
PL../3

	Pag. Page <i>Seite</i>
PL 63, MPL 63	30
PL 63/3, MPL 63/3	31
PL 80, MPL 80	32
PL 80/3, MPL 80/3	33
PL 100, MPL 100	34
PL 100/3, MPL 100/3	35
PL 125, MPL 125	36
PL 125/3, MPL 125/3	37
PL 160, MPL 160	38
PL 160/3, MPL 160/3	39

PL 63

PRESTAZIONI

PERFORMANCES

LEISTUNG

MPL 63

n ₁	i	n ₂	M ₂ (Nm)	kW ₁	HP ₁	RD
2800	10.60	264	180	5.2	7.1	0.96
	13.65	205	180	4.0	5.5	0.96
	15.01	187	180	3.7	5.0	0.96
	17.97	156	216	3.7	5.0	0.96
	18.71	150	153	2.5	3.4	0.96
	23.12	121	207	2.7	3.7	0.96
	25.42	110	207	2.5	3.4	0.96
	31.69	88	162	1.6	2.1	0.96

n ₁	i	n ₂	M ₂ (Nm)	kW ₁	HP ₁	RD	fs	P.A.M.
2800	10.60	264	76	2.2	3	0.96	2.36	24/200 - 19/200
	13.65	205	98	2.2	3	0.96	1.83	24/200 - 19/200
	15.01	187	108	2.2	3	0.96	1.66	24/200 - 19/200
	17.97	156	129	2.2	3	0.96	1.67	24/200 - 19/200
	18.71	150	135	2.2	3	0.96	1.14	24/200 - 19/200
	23.12	121	167	2.2	3	0.96	1.24	24/200 - 19/200
	25.42	110	125	1.5	2	0.96	1.66	24/200 - 19/200
	31.69	88	156	1.5	2	0.96	1.04	24/200 - 19/200

n ₁	i	n ₂	M ₂ (Nm)	kW ₁	HP ₁	RD
1400	10.60	132	200	2.9	3.9	0.96
	13.65	103	200	2.2	3.0	0.96
	15.01	93	200	2.0	2.8	0.96
	17.97	78	240	2.0	2.8	0.96
	18.71	75	170	1.4	1.9	0.96
	23.12	61	230	1.5	2.1	0.96
	25.42	55	230	1.4	1.9	0.96
	31.69	44	180	0.9	1.2	0.96

n ₁	i	n ₂	M ₂ (Nm)	kW ₁	HP ₁	RD	fs	P.A.M.
1400	10.60	132	125	1.8	2.5	0.96	1.60	24/200 - 19/200
	13.65	103	161	1.8	2.5	0.96	1.24	24/200 - 19/200
	15.01	93	177	1.8	2.5	0.96	1.13	24/200 - 19/200
	17.97	78	212	1.8	2.5	0.96	1.13	24/200 - 19/200
	18.71	75	184	1.5	2	0.96	0.92	24/200 - 19/200
	23.12	61	227	1.5	2	0.96	1.01	24/200 - 19/200
	25.42	55	183	1.1	1.5	0.96	1.26	24/200 - 19/200
	31.69	44	156	0.75	1	0.96	1.16	24/200 - 19/200

n ₁	i	n ₂	M ₂ (Nm)	kW ₁	HP ₁	RD
900	10.60	85	220	2.0	2.8	0.96
	13.65	66	220	1.6	2.2	0.96
	15.01	60	220	1.4	2.0	0.96
	17.97	50	264	1.4	2.0	0.96
	18.71	48	187	1.0	1.3	0.96
	23.12	39	253	1.1	1.5	0.96
	25.42	35	253	1.0	1.3	0.96
	31.69	28	198	0.6	0.8	0.96

n ₁	i	n ₂	M ₂ (Nm)	kW ₁	HP ₁	RD	fs	P.A.M.
900	10.60	85	119	1.1	1.5	0.96	1.85	24/200 - 19/200
	13.65	66	153	1.1	1.5	0.96	1.44	24/200 - 19/200
	15.01	60	168	1.1	1.5	0.96	1.31	24/200 - 19/200
	17.97	50	201	1.1	1.5	0.96	1.31	24/200 - 19/200
	18.71	48	210	1.1	1.5	0.96	0.89	24/200 - 19/200
	23.12	39	259	1.1	1.5	0.96	0.98	24/200 - 19/200
	25.42	35	194	0.75	1	0.96	1.30	24/200 - 19/200
	31.69	28	178	0.55	0.75	0.96	1.12	24/200 - 19/200

DIMENSIONI D'INGOMBRO

OVERALL DIMENSIONS

ALLGEMEINE ABMESSUNGEN

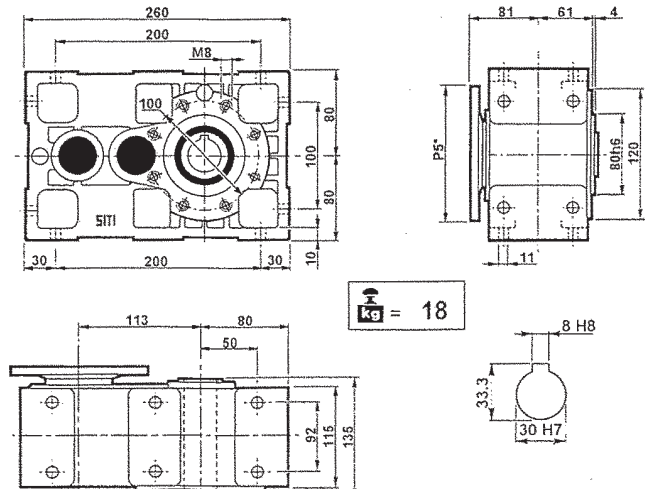
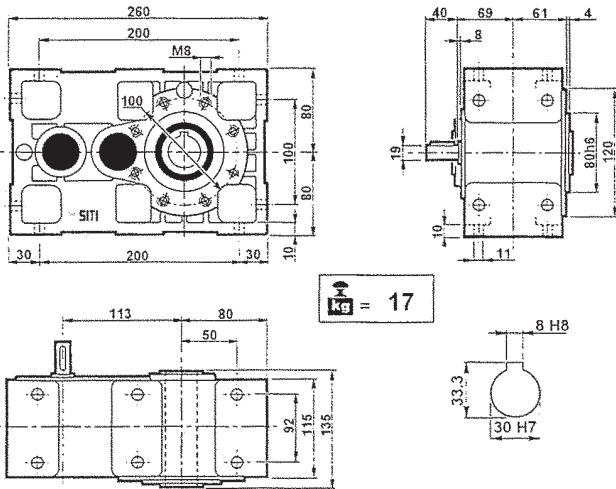

PL 63

MPL 63

P₅* : Vedere i PAM per ogni singola versione

P₅* : See PAM size for each single version

P₅* : Siehe PAM Grösse für jede Ausführung

CARICHI RADIALI (N)

OVERHUNG LOADS (N)

RADIALE BELASTUNGEN (N)

ALBERO VELOCE / INPUT SHAFT / EINGANGSWELLE		
1400 min ⁻¹	PL 63	PL 63/3
	650	400

ALBERO LENTO / OUTPUT SHAFT / ABTRIEBSWELLE							
PL 63 - PL 63/3							
min ⁻¹	0°	30°	60°	90°	120°	150°	180°
20	9205	9517	10327	11572	13002	14121	14562
40	6961	7276	8022	9267	10700	11880	12320
60	5911	6159	6907	8150	9582	10762	11259
80	5164	5413	6159	7404	8836	10079	10514
100	4666	4916	5598	6838	8271	9500	10016
120	4291	4480	5225	6409	7902	9145	9643
140	3982	4156	4848	5946	7332	8486	8948
160	3732	3896	4544	5574	6872	7954	8386

Rotazione oraria
Clockwise
rotation
Uhrzeigersinn

Rotazione antioraria
Anticlockwise
rotation
Gegenuhrzeigersinn

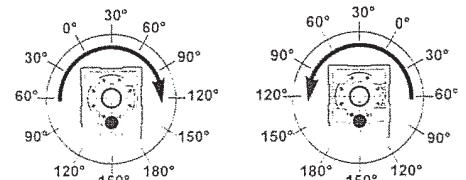

PL 63/3

PRESTAZIONI

PERFORMANCES

LEISTUNG

MPL 63/3

n_1	i	n_2	M_2 (Nm)	kW_1	HP_1	RD
2800	29.25	96	252	2.7	3.7	0.92
	37.68	74	270	2.3	3.1	0.92
	41.43	68	252	1.9	2.6	0.92
	47.53	59	180	1.2	1.6	0.92
	51.66	54	198	1.2	1.7	0.92
	58.72	48	270	1.5	2.0	0.92
	64.55	43	252	1.2	1.7	0.92
	67.37	42	198	0.9	1.3	0.92
	80.5	35	198	0.8	1.1	0.92
	83.22	34	270	1.0	1.4	0.92
	91.49	31	252	0.9	1.2	0.92
114.09	25	198	0.6	0.8	0.92	

n_1	i	n_2	M_2 (Nm)	kW_1	HP_1	RD	f_s	P.A.M.
2800	29.25	96	138	1.5	2	0.92	1.83	19/200 - 14/160
	37.68	74	177	1.5	2	0.92	1.52	19/200 - 14/160
	41.43	68	195	1.5	2	0.92	1.29	19/200 - 14/160
	47.53	59	112	0.75	1	0.92	1.61	14/160
	51.66	54	178	1.1	1.5	0.92	1.11	19/200 - 14/160
	58.72	48	138	0.75	1	0.92	1.95	14/160
	64.55	43	152	0.75	1	0.92	1.66	14/160
	67.37	42	53	0.25	0.34	0.92	3.75	11/140
	80.5	35	189	0.75	1	0.92	1.05	14/160
	83.22	34	65	0.25	0.34	0.92	4.14	11/140
	91.49	31	72	0.25	0.34	0.92	3.51	11/140
114.09	25	89	0.25	0.34	0.92	2.21	11/140	

1400	29.25	48	280	1.5	2.1	0.92
	37.68	37	300	1.3	1.7	0.92
	41.43	34	280	1.1	1.5	0.92
	47.53	29	200	0.7	0.9	0.92
	51.66	27	220	0.7	0.9	0.92
	58.72	24	300	0.8	1.1	0.92
	64.55	22	280	0.7	0.9	0.92
	67.37	21	220	0.5	0.7	0.92
	80.5	17	220	0.4	0.6	0.92
	83.22	17	300	0.6	0.8	0.92
	91.49	15	280	0.5	0.7	0.92
114.09	12	220	0.3	0.4	0.92	

1400	29.25	48	138	0.75	1	0.92	2.03	19/200 - 14/160
	37.68	37	177	0.75	1	0.92	1.69	19/200 - 14/160
	41.43	34	195	0.75	1	0.92	1.44	19/200 - 14/160
	47.53	29	110	0.37	0.5	0.92	1.81	14/160
	51.66	27	243	0.75	1	0.92	0.90	19/200 - 14/160
	58.72	24	136	0.37	0.5	0.92	2.20	14/160
	64.55	22	150	0.37	0.5	0.92	1.87	14/160
	67.37	21	76	0.18	0.25	0.92	2.89	11/140
	80.5	17	187	0.37	0.50	0.92	1.18	14/160
	83.22	17	94	0.18	0.25	0.92	3.19	11/140
	91.49	15	103	0.18	0.25	0.92	2.71	11/140
114.09	12	129	0.18	0.25	0.92	1.71	11/140	

900	29.25	31	308	1.1	1.5	0.92
	37.68	24	330	0.9	1.2	0.92
	41.43	22	308	0.8	1.0	0.92
	47.53	19	220	0.5	0.6	0.92
	51.66	17	242	0.5	0.7	0.92
	58.72	15	330	0.6	0.8	0.92
	64.55	14	308	0.5	0.7	0.92
	67.37	13	242	0.4	0.5	0.92
	80.5	11	242	0.3	0.4	0.92
	83.22	11	330	0.4	0.6	0.92
	91.49	10	308	0.3	0.5	0.92
114.09	8	242	0.2	0.3	0.92	

900	29.25	31	157	0.55	0.75	0.92	1.96	19/200 - 14/160
	37.68	24	202	0.55	0.75	0.92	1.63	19/200 - 14/160
	41.43	22	222	0.55	0.75	0.92	1.38	19/200 - 14/160
	47.53	19	216	0.25	0.34	0.92	1.90	14/160
	51.66	17	277	0.55	0.75	0.92	0.87	19/200 - 14/160
	58.72	15	143	0.25	0.34	0.92	2.30	14/160
	64.55	14	158	0.25	0.34	0.92	1.96	14/160
	67.37	13	79	0.12	0.16	0.92	3.07	11/140
	80.5	11	196	0.25	0.34	0.92	1.23	14/160
	83.22	11	97	0.12	0.16	0.92	3.8	11/140
	91.49	10	107	0.12	0.16	0.92	2.87	11/140
114.09	8	134	0.12	0.16	0.92	1.81	11/140	

DIMENSIONI D'INGOMBRO

OVERALL DIMENSIONS

ALLGEMEINE ABMESSUNGEN

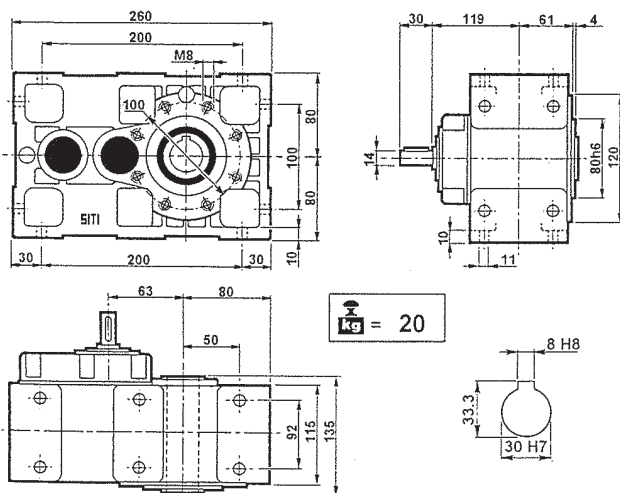

PL 63 /3

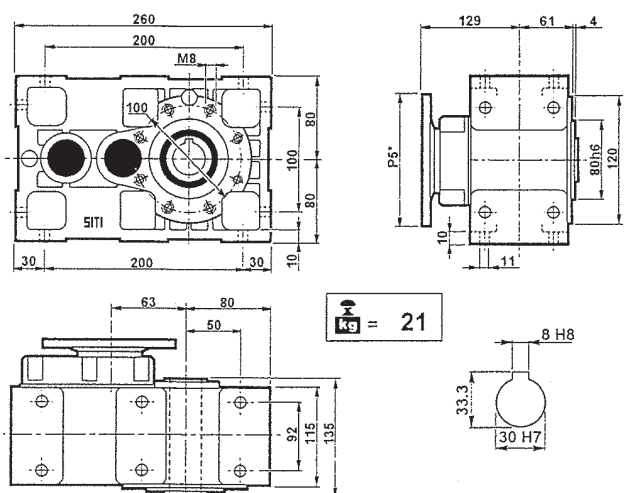

MPL 63 /3

P_5^* : Vedere i PAM per ogni singola versione
 P_5^* : See PAM size for each single version
 P_5^* : Siehe PAM Grösse für jede Ausführung

PL 80

PRESTAZIONI

PERFORMANCES

LEISTUNG

MPL 80

n ₁	i	n ₂	M ₂ (Nm)	kW ₁	HP ₁	RD
----------------	---	----------------	------------------------	-----------------	-----------------	----

2800	10.02	279	360	11.0	14.9	0.96
	12.94	216	360	8.5	11.6	0.96
	15.78	177	360	7.0	9.5	0.96
	17.95	156	441	7.5	10.2	0.96
	20.17	139	405	6.1	8.3	0.96
	23.17	121	378	5.0	6.8	0.96
	28.26	99	378	4.1	5.6	0.96
	36.13	77	360	3.0	4.1	0.96

1400	10.02	140	400	6.1	8.3	0.96
	12.94	108	400	4.7	6.4	0.96
	15.78	89	400	3.9	5.3	0.96
	17.95	78	490	4.2	5.7	0.96
	20.17	69	450	3.4	4.6	0.96
	23.17	60	420	2.8	3.8	0.96
	28.26	50	420	2.3	3.1	0.96
	36.13	39	400	1.7	2.3	0.96

900	10.02	90	440	4.3	5.9	0.96
	12.94	70	440	3.3	4.5	0.96
	15.78	57	440	2.7	3.7	0.96
	17.95	50	539	2.9	4.0	0.96
	20.17	45	495	2.4	3.3	0.96
	23.17	39	462	2.0	2.7	0.96
	28.26	32	462	1.6	2.2	0.96
	36.13	25	440	1.2	1.6	0.96

n ₁	i	n ₂	M ₂ (Nm)	kW ₁	HP ₁	RD	fs	P.A.M.
----------------	---	----------------	------------------------	-----------------	-----------------	----	----	--------

2800	10.02	279	180	5.5	7.5	0.96	2.00	28/250 - 24/200
	12.94	216	233	5.5	7.5	0.96	1.54	28/250 - 24/200
	15.78	177	284	5.5	7.5	0.96	1.27	28/250 - 24/200
	17.95	156	323	5.5	7.5	0.96	1.36	28/250 - 24/200
	20.17	139	363	5.5	7.5	0.96	1.11	28/250 - 24/200
	23.17	121	303	4	5.5	0.96	1.25	28/250 - 24/200
	28.26	99	370	4	5.5	0.96	1.02	28/250 - 24/200
	36.13	77	260	2.2	3	0.96	1.38	28/250 - 24/200

1400	10.02	140	262	4	5.5	0.96	1.52	28/250 - 24/200
	12.94	108	339	4	5.5	0.96	1.18	28/250 - 24/200
	15.78	89	310	3	4	0.96	1.29	28/250 - 24/200
	17.95	78	470	4	5.5	0.96	1.04	28/250 - 24/200
	20.17	69	396	3	4	0.96	1.14	28/250 - 24/200
	23.17	60	334	2.2	3	0.96	1.26	28/250 - 24/200
	28.26	50	407	2.2	3	0.96	1.03	28/250 - 24/200
	36.13	39	365	1.5	2	0.96	1.13	28/250 - 24/200

900	10.02	90	225	2.2	3	0.96	1.96	28/250 - 24/200
	12.94	70	290	2.2	3	0.96	1.52	28/250 - 24/200
	15.78	57	354	2.2	3	0.96	1.24	28/250 - 24/200
	17.95	50	402	2.2	3	0.96	1.34	28/250 - 24/200
	20.17	45	452	2.2	3	0.96	1.10	28/250 - 24/200
	23.17	39	354	1.5	2	0.96	1.30	28/250 - 24/200
	28.26	32	432	1.5	2	0.96	1.07	28/250 - 24/200
	36.13	25	405	1.1	1.5	0.96	1.09	28/250 - 24/200

DIMENSIONI D'INGOMBRO

OVERALL DIMENSIONS

ALLGEMEINE ABMESSUNGEN

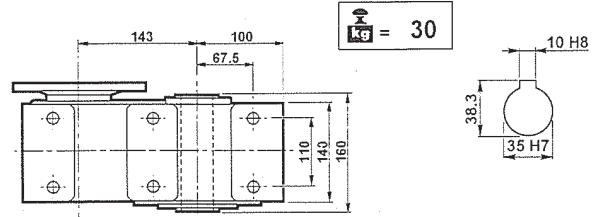
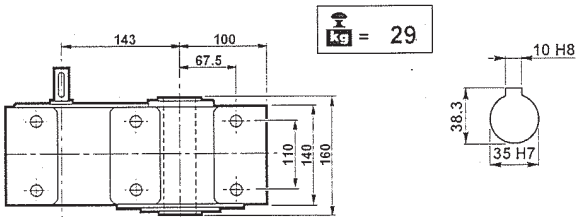
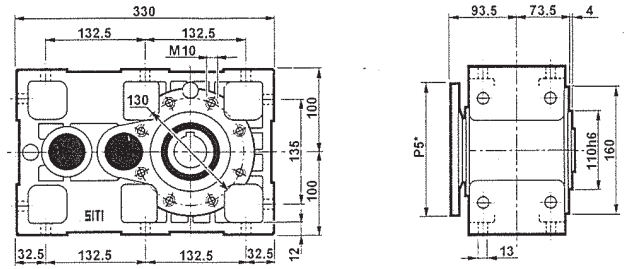
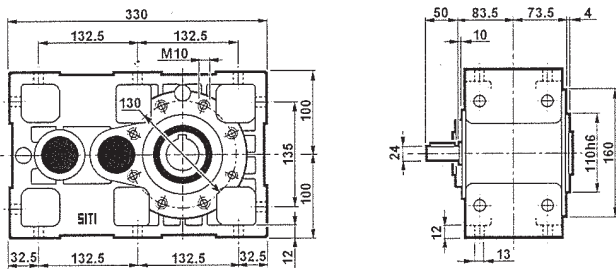

PL 80

MPL 80

P₅* : Vedere i PAM per ogni singola versione
P₅* : See PAM size for each single version
P₅* : Siehe PAM Grösse für jede Ausführung

CARICHI RADIALI (N)

OVERHUNG LOADS (N)

RADIALE BELASTUNGEN (N)

ALBERO VELOCE / INPUT SHAFT / EINGANGSWELLE		
	PL 80	PL 80/3
1400 min ⁻¹	900	650

ALBERO LENTO / OUTPUT SHAFT / ABTRIEBSWELLE							
PL 80 - PL 80/3							
min ⁻¹	0°	30°	60°	90°	120°	150°	180°
20	9995	10333	11213	12565	14118	15332	15811
40	7558	7900	8710	10062	11618	12899	13377
60	6418	6687	7499	8849	10403	11685	12225
80	5607	5878	6687	8039	9594	10944	11416
100	5066	5337	6078	7425	8981	10314	10375
120	4659	4864	5673	6959	8580	9930	10470
140	4323	4513	5264	6457	7961	9214	9715
160	4052	4230	4934	6052	7462	8636	9106

Rotazione oraria
Clockwise
rotation
Uhrzeigersinn

Rotazione antioraria
Anticlockwise
rotation
Gegenuhrzeigersinn

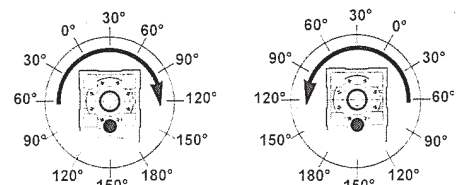

PL 80/3

PRESTAZIONI

PERFORMANCES

LEISTUNG

MPL 80/3

n ₁	i	n ₂	M ₂ (Nm)	kW ₁	HP ₁	RD
2800	24.45	115	459	6.0	8.1	0.92
	31.57	89	459	4.6	6.3	0.92
	38.47	73	450	3.7	5.1	0.92
	46.91	60	432	2.9	4.0	0.92
	49.22	57	360	2.3	3.2	0.92
	56.54	50	459	2.6	3.5	0.92
	59.97	47	360	1.9	2.6	0.92
	68.95	41	441	2.0	2.8	0.92
	84.58	33	468	1.8	2.4	0.92
	88.15	32	378	1.4	1.9	0.92
	103.15	27	450	1.4	1.9	0.92
	131.86	21	378	0.9	1.2	0.92

n ₁	i	n ₂	M ₂ (Nm)	kW ₁	HP ₁	RD	P.A.M.	
2800	24.45	115	169	2.2	3	0.92	2.72	24/200 - 19/200
	31.57	89	218	2.2	3	0.92	2.11	24/200 - 19/200
	38.47	73	362	3	4	0.92	1.24	28/250 - 24/200
	46.91	60	442	3	4	0.92	0.98	28/250 - 24/200
	49.22	57	340	2.2	3	0.92	1.06	24/200 - 19/200
	56.54	50	390	2.2	3	0.92	1.18	24/200 - 19/200
	59.97	47	282	1.5	2	0.92	1.28	28/250 - 24/200
	68.95	41	325	1.5	2	0.92	1.36	24/200 - 19/200
	84.58	33	199	0.75	1	0.92	2.35	14/160
	88.15	32	304	1.10	1.5	0.92	1.24	24/200 - 19/200
	103.15	27	243	0.75	1	0.92	1.85	14/160
	131.86	21	310	0.75	1	0.92	1.22	14/160

1400	24.45	57	510	3.3	4.5	0.92
	31.57	44	510	2.6	3.5	0.92
	38.47	36	500	2.1	2.8	0.92
	46.91	30	480	1.6	2.2	0.92
	49.22	28	400	1.3	1.8	0.92
	56.54	25	510	1.4	2.0	0.92
	59.97	23	400	1.1	1.4	0.92
	68.95	20	490	1.1	1.5	0.92
	84.58	17	520	1.0	1.3	0.92
	88.15	16	420	0.8	1.0	0.92
	103.15	14	500	0.8	1.1	0.92
	131.86	11	420	0.5	0.7	0.92

1400	24.45	57	276	1.8	2.5	0.92	1.85	24/200 - 19/200
	31.57	44	357	1.8	2.5	0.92	1.43	24/200 - 19/200
	38.47	36	531	2.2	3	0.92	0.94	28/250 - 24/200
	46.91	30	442	1.5	2	0.92	1.09	28/250 - 24/200
	49.22	28	340	1.1	1.5	0.92	1.18	24/200 - 19/200
	56.54	25	390	1.1	1.5	0.92	1.31	24/200 - 19/200
	59.97	23	414	1.1	1.5	0.92	0.97	28/250 - 24/200
	68.95	20	476	1.1	1.5	0.92	1.03	24/200 - 19/200
	84.58	17	196	0.37	0.5	0.92	2.65	14/160
	88.15	16	415	0.75	1	0.92	1.01	24/200 - 19/200
	103.15	14	240	0.37	0.5	0.92	2.09	14/160
	131.86	11	306	0.37	0.5	0.92	1.37	14/160

900	24.45	37	561	2.4	3.2	0.92
	31.57	29	561	1.8	2.5	0.92
	38.47	23	550	1.5	2.0	0.92
	46.91	19	528	1.2	1.6	0.92
	49.22	18	440	0.9	1.2	0.92
	56.54	16	561	1.0	1.4	0.92
	59.97	15	440	0.8	1.0	0.92
	68.95	13	539	0.8	1.1	0.92
	84.58	11	572	0.7	0.9	0.92
	88.15	10	462	0.5	0.7	0.92
	103.15	9	550	0.5	0.7	0.92
	131.86	7	462	0.4	0.5	0.92

900	24.45	37	263	1.1	1.5	0.92	2.14	24/200 - 19/200
	31.57	29	339	1.1	1.5	0.92	1.65	24/200 - 19/200
	38.47	23	563	1.5	2	0.92	0.98	28/250 - 24/200
	46.91	19	504	1.1	1.5	0.92	1.05	28/250 - 24/200
	49.22	18	360	0.75	1	0.92	1.22	24/200 - 19/200
	56.54	16	414	0.75	1	0.92	1.36	24/200 - 19/200
	59.97	15	439	0.75	1	0.92	1.00	28/250 - 24/200
	68.95	13	505	0.75	1	0.92	1.07	24/200 - 19/200
	84.58	11	206	0.25	0.34	0.92	2.77	14/160
	88.15	10	473	0.55	0.75	0.92	0.89	24/200 - 19/200
	103.15	9	252	0.25	0.34	0.92	2.18	14/160
	131.86	7	322	0.25	0.34	0.92	1.44	14/160

DIMENSIONI D'INGOMBRO

OVERALL DIMENSIONS

ALLGEMEINE ABMESSUNGEN

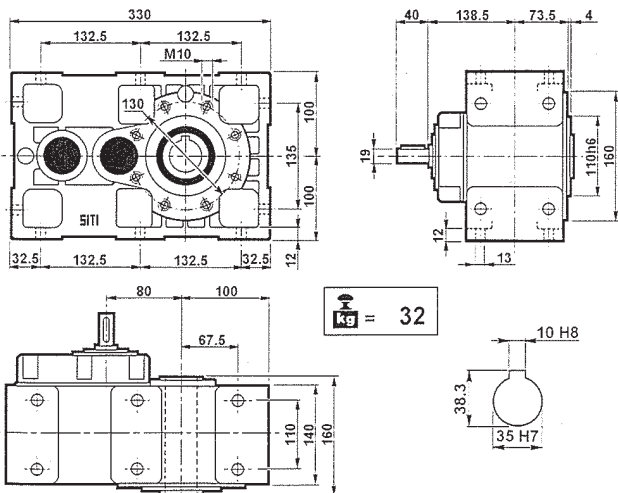

PL 80/3

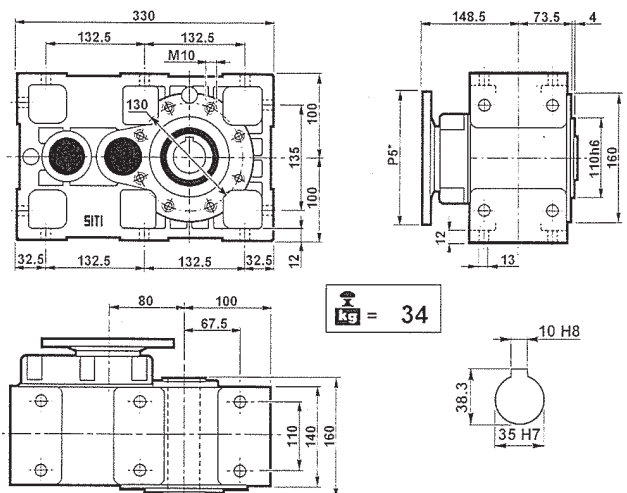

MPL 80/3

P₅* : Vedere i PAM per ogni singola versione
P₅* : See PAM size for each single version
P₅* : Siehe PAM Grösse für jede Ausführung

PL 100

PRESTAZIONI

n ₁	i	n ₂	M ₂ (Nm)	kW ₁	HP ₁	RD
2800	9.98	281	720	22.0	30.0	0.96
	12.89	217	720	17.1	23.2	0.96
	15.47	181	855	16.9	23.0	0.96
	15.72	178	720	14.0	19.0	0.96
	19.98	140	810	12.4	16.8	0.96
	20.49	137	675	10.1	13.7	0.96
	24.36	115	810	10.2	13.8	0.96
	31.75	88	675	6.5	8.8	0.96
1400	9.98	140	800	12.2	16.6	0.96
	12.89	109	800	9.5	12.9	0.96
	15.47	90	950	9.4	12.8	0.96
	15.72	89	800	7.8	10.6	0.96
	19.98	70	900	6.9	9.4	0.96
	20.49	68	750	5.6	7.6	0.96
	24.36	57	900	5.6	7.7	0.96
	31.75	44	750	3.6	4.9	0.96
900	9.98	90	880	8.7	11.8	0.96
	12.89	70	880	6.7	9.1	0.96
	15.47	58	1045	6.6	9.0	0.96
	15.72	57	880	5.5	7.5	0.96
	19.98	45	990	4.9	6.6	0.96
	20.49	44	825	4.0	5.4	0.96
	24.36	37	990	4.0	5.4	0.96
	31.75	28	825	2.6	3.5	0.96

PERFORMANCES

LEISTUNG

MPL 100

n ₁	i	n ₂	M ₂ (Nm)	kW ₁	HP ₁	RD	fs	P.A.M.
2800	9.98	281	359	11	15	0.96	2.01	38/300 - 28/250
	12.89	217	464	11	15	0.96	1.55	38/300 - 28/250
	15.47	178	557	11	15	0.96	1.54	38/300 - 28/250
	15.72	137	566	11	15	0.96	1.27	38/300 - 28/250
	19.98	181	720	11	15	0.96	1.13	38/300 - 28/250
	20.49	140	604	9	12.5	0.96	1.12	38/300 - 28/250
	24.36	115	718	9	12.5	0.96	1.13	38/300 - 28/250
	31.75	88	672	5.5	7.5	0.96	1.18	38/300 - 28/250
1400	9.98	140	719	11	15	0.96	1.11	38/300 - 28/250
	12.89	109	777	9.2	12.5	0.96	1.03	38/300 - 28/250
	15.47	90	932	9.2	12.5	0.96	1.02	38/300 - 28/250
	15.72	89	772	7.5	10	0.96	1.04	38/300 - 28/250
	19.98	70	720	5.5	7.5	0.96	1.25	38/300 - 28/250
	20.49	68	738	5.5	7.5	0.96	1.02	38/300 - 28/250
	24.36	57	877	5.5	7.5	0.96	1.03	38/300 - 28/250
	31.75	44	624	3	4	0.96	1.20	38/300 - 28/250
900	9.98	90	559	5.5	7.5	0.96	1.57	38/300 - 28/250
	12.89	70	722	5.5	7.5	0.96	1.22	38/300 - 28/250
	15.47	58	867	5.5	7.5	0.96	1.21	38/300 - 28/250
	15.72	57	881	5.5	7.5	0.96	1.00	38/300 - 28/250
	19.98	45	814	4	5.5	0.96	1.22	38/300 - 28/250
	20.49	44	835	4	5.5	0.96	0.99	38/300 - 28/250
	24.36	37	993	4	5.5	0.96	1.00	38/300 - 28/250
	31.75	28	712	2.2	3	0.96	1.16	38/300 - 28/250

DIMENSIONI D'INGOMBRO

OVERALL DIMENSIONS

ALLGEMEINE ABMESSUNGEN

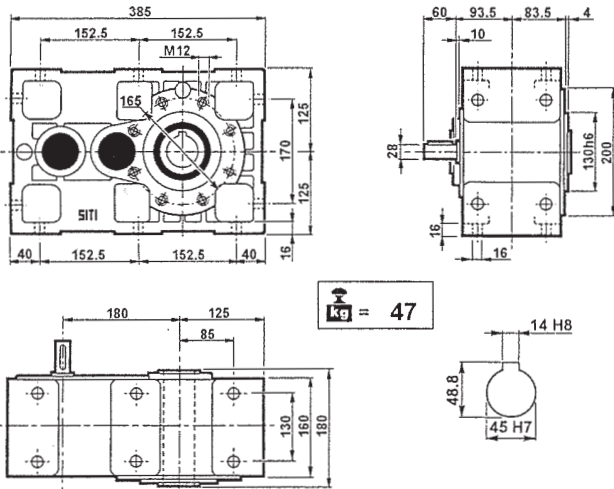

PL 100

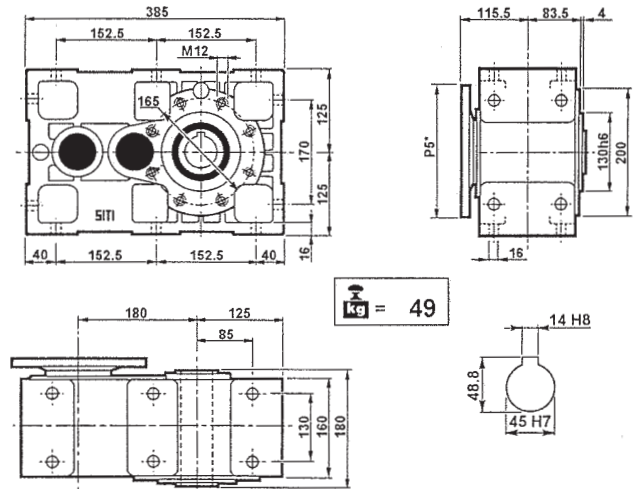

MPL 100

P₅* : Vedere i PAM per ogni singola versione
P₅* : See PAM size for each single version
P₅* : Siehe PAM Grösse für jede Ausführung

CARICHI RADIALI (N)

OVERHUNG LOADS (N)

RADIALE BELASTUNGEN (N)

ALBERO VELOCE / INPUT SHAFT / EINGANGSWELLE		
1400 min ⁻¹	PL 100	PL 100/3
	1400	1000

ALBERO LENTO / OUTPUT SHAFT / ABTRIEBSWELLE							
PL 100 - PL 100/3							
min ⁻¹	0°	30°	60°	90°	120°	150°	180°
20	13186	13632	14793	16577	18625	20227	20859
40	9972	10422	11491	13274	15327	17017	17646
60	8467	8822	9893	11674	13725	15415	16128
80	7397	7754	8822	10606	12657	14438	15060
100	6684	7041	8019	9795	11848	13607	14347
120	6147	6417	7485	9180	11319	13100	13813
140	5704	5954	6945	8518	10502	12155	12817
160	5346	5580	6509	7984	9844	11393	12013

Rotazione oraria
Clockwise
rotation
Uhrzeigersinn

Rotazione antioraria
Anticlockwise
rotation
Gegenuhrzeigersinn

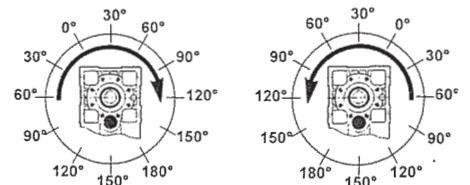

PL 100/3

PRESTAZIONI

PERFORMANCES

LEISTUNG

MPL 100/3

n ₁	i	n ₂	M ₂ (Nm)	kW ₁	HP ₁	RD
2800	21.40	131	810	12.1	16.4	0.92
	25.68	109	900	11.2	15.2	0.92
	33.16	84	882	8.5	11.5	0.92
	37.74	74	918	7.8	10.5	0.92
	40.44	69	882	7.0	9.5	0.92
	48.74	57	900	5.9	8.0	0.92
	52.70	53	720	4.4	5.9	0.92
	59.44	47	900	4.8	6.6	0.92
	72.91	38	918	4.0	5.5	0.92
	77.47	36	720	3.0	4.0	0.92
	88.91	31	918	3.3	4.5	0.92
115.88	24	720	2.0	2.7	0.92	

n ₁	i	n ₂	M ₂ (Nm)	kW ₁	HP ₁	RD	fs	P.A.M.
2800	21.40	131	369	5.5	7.5	0.92	2.19	28/250 - 24/200
	25.68	109	443	5.5	7.5	0.92	2.03	28/250 - 24/200
	33.16	84	572	5.5	7.5	0.92	1.54	28/250 - 24/200
	37.74	74	261	2.2	3	0.92	3.52	24/200 - 19/200
	40.44	69	698	5.5	7.5	0.92	1.26	28/250 - 24/200
	48.74	57	336	2.2	3	0.92	2.67	24/200 - 19/200
	52.70	53	661	4	5.5	0.92	1.09	28/250 - 24/200
	59.44	47	410	2.2	3	0.92	2.19	24/200 - 19/200
	72.91	38	343	1.5	2	0.92	2.68	14/160
	77.47	36	535	2.2	3	0.92	1.35	24/200 - 19/200
	88.91	31	418	1.5	2	0.92	2.19	14/160
115.88	24	545	1.5	2	0.92	1.32	14/160	

n ₁	i	n ₂	M ₂ (Nm)	kW ₁	HP ₁	RD
1400	21.40	65	900	6.7	9.1	0.92
	25.68	55	1000	6.2	8.4	0.92
	33.16	42	980	4.7	6.4	0.92
	37.74	37	1020	4.3	5.9	0.92
	40.44	35	980	3.9	5.3	0.92
	48.74	29	1000	3.3	4.4	0.92
	52.70	27	800	2.4	3.3	0.92
	59.44	24	1000	2.7	3.6	0.92
	72.91	19	1020	2.2	3.0	0.92
	77.47	18	800	1.6	2.2	0.92
	88.91	16	1020	1.8	2.5	0.92
115.88	12	800	1.1	1.5	0.92	

n ₁	i	n ₂	M ₂ (Nm)	kW ₁	HP ₁	RD	fs	P.A.M.
1400	21.40	65	537	4	5.5	0.92	1.68	28/250 - 24/200
	25.68	55	645	4	5.5	0.92	1.55	28/250 - 24/200
	33.16	42	832	4	5.5	0.92	1.18	28/250 - 24/200
	37.74	37	426	1.8	2.5	0.92	2.39	24/200 - 19/200
	40.44	35	1015	4	5.5	0.92	0.97	28/250 - 24/200
	48.74	29	551	1.8	2.5	0.92	1.82	24/200 - 19/200
	52.70	27	728	2.2	3	0.92	1.10	28/250 - 24/200
	59.44	24	671	1.8	2.5	0.92	1.49	24/200 - 19/200
	72.91	19	343	0.75	1	0.92	2.97	14/160
	77.47	18	729	1.5	2	0.92	1.10	24/200 - 19/200
	88.91	16	418	0.75	1	0.92	2.44	14/160
115.88	12	545	0.75	1	0.92	1.47	14/160	

n ₁	i	n ₂	M ₂ (Nm)	kW ₁	HP ₁	RD
900	21.40	42	990	4.7	6.4	0.92
	25.68	35	1100	4.4	6.0	0.92
	33.16	27	1078	3.3	4.5	0.92
	37.74	24	1122	3.0	4.1	0.92
	40.44	22	1078	2.7	3.7	0.92
	48.74	18	1100	2.3	3.1	0.92
	52.70	17	880	1.7	2.3	0.92
	59.44	15	1100	1.9	2.6	0.92
	72.91	12	1122	1.6	2.1	0.92
	77.47	12	880	1.2	1.6	0.92
	88.91	10	1122	1.3	1.8	0.92
115.88	8	880	0.8	1.1	0.92	

n ₁	i	n ₂	M ₂ (Nm)	kW ₁	HP ₁	RD	fs	P.A.M.
900	21.40	42	460	2.2	3	0.92	2.15	28/250 - 24/200
	25.68	35	552	2.2	3	0.92	1.99	28/250 - 24/200
	33.16	27	712	2.2	3	0.92	1.51	28/250 - 24/200
	37.74	24	405	1.1	1.5	0.92	2.77	24/200 - 19/200
	40.44	22	869	2.2	3	0.92	1.24	28/250 - 24/200
	48.74	18	523	1.1	1.5	0.92	2.10	24/200 - 19/200
	52.70	17	926	1.8	2.5	0.92	0.95	28/250 - 24/200
	59.44	15	638	1.1	1.5	0.92	1.72	24/200 - 19/200
	72.91	12	391	0.55	0.75	0.92	2.87	14/160
	77.47	12	832	1.1	1.5	0.92	1.06	24/200 - 19/200
	88.91	10	477	0.55	0.75	0.92	2.35	14/160
115.88	8	622	0.55	0.75	0.92	1.41	14/160	

DIMENSIONI D'INGOMBRO

OVERALL DIMENSIONS

ALLGEMEINE ABMESSUNGEN

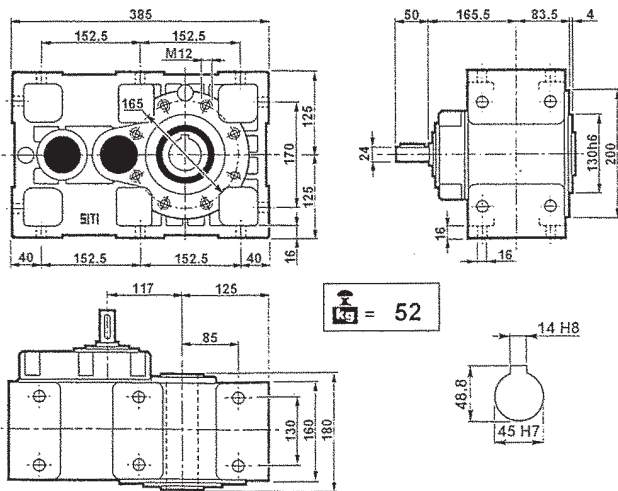

PL 100/3

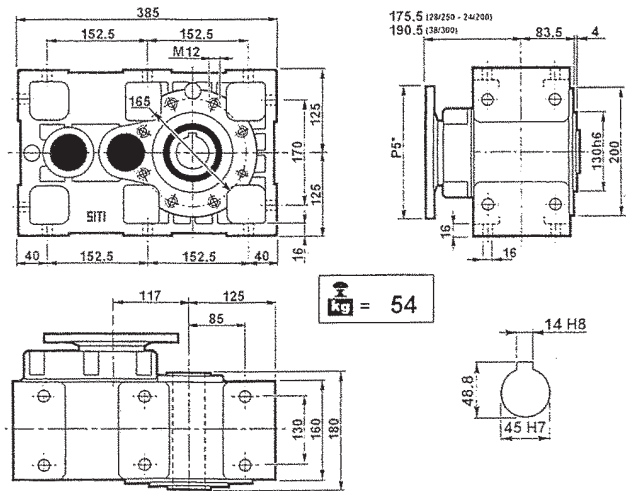

MPL 100/3

P₅* : Vedere i PAM per ogni singola versione
P₅* : See PAM size for each single version
P₅* : Siehe PAM Grösse für jede Ausführung

PL 125

PRESTAZIONI

PERFORMANCES

LEISTUNG

MPL 125

n ₁	i	n ₂	M ₂ (Nm)	kW ₁	HP ₁	RD
2800	10.48	267	1440	42.0	57.1	0.96
	13.49	208	1440	32.6	44.3	0.96
	16.28	172	1440	27.0	36.7	0.96
	16.43	170	1305	24.3	33.0	0.96
	18.60	151	1620	26.6	36.2	0.96
	20.96	134	1530	22.3	30.3	0.96
	25.52	110	1485	17.8	24.2	0.96
	28.90	97	1305	13.8	18.8	0.96

n ₁	i	n ₂	M ₂ (Nm)	kW ₁	HP ₁	RD	fs	P.A.M.
2800	10.48	267	635	18.5	25	0.96	2.27	42/350 - 38/300
	13.49	208	817	18.5	25	0.96	1.76	42/350 - 38/300
	16.28	172	986	18.5	25	0.96	1.46	42/350 - 38/300
	16.43	170	995	18.5	25	0.96	1.31	42/350 - 38/300
	18.60	151	1127	18.5	25	0.96	1.44	42/350 - 38/300
	20.96	134	1270	18.5	25	0.96	1.21	42/350 - 38/300
	25.52	110	1253	15	20	0.96	1.18	42/350 - 38/300
	28.90	97	1041	11	15	0.96	1.25	42/350 - 38/300

1400	10.48	134	1600	23.3	31.7	0.96
	13.49	104	1600	18.1	24.6	0.96
	16.28	86	1600	15.0	20.4	0.96
	16.43	85	1450	13.5	18.3	0.96
	18.60	75	1800	14.8	20.1	0.96
	20.96	67	1700	12.4	16.8	0.96
	25.52	55	1650	9.9	13.4	0.96
	28.90	48	1450	7.7	10.4	0.96

1400	10.48	134	1029	15	20	0.96	1.55	42/350 - 38/300
	13.49	104	1325	15	20	0.96	1.21	42/350 - 38/300
	16.28	86	1599	15	20	0.96	1.00	42/350 - 38/300
	16.43	85	1184	11	15	0.96	1.23	42/350 - 38/300
	18.60	75	1827	15	20	0.96	0.99	42/350 - 38/300
	20.96	67	1510	11	15	0.96	1.13	42/350 - 38/300
	25.52	55	1537	9.2	12.5	0.96	1.07	42/350 - 38/300
	28.90	48	1419	7.5	10	0.96	1.02	42/350 - 38/300

900	10.48	86	1760	16.5	22.4	0.96
	13.49	67	1760	12.8	17.4	0.96
	16.28	55	1760	10.6	14.4	0.96
	16.43	55	1595	9.5	13.0	0.96
	18.60	48	1980	10.5	14.2	0.96
	20.96	43	1870	8.8	11.9	0.96
	25.52	35	1815	7.0	9.5	0.96
	28.90	31	1595	5.4	7.4	0.96

900	10.48	86	1174	11	15	0.96	1.50	42/350 - 38/300
	13.49	67	1512	11	15	0.96	1.16	42/350 - 38/300
	16.28	55	1824	11	15	0.96	0.96	42/350 - 38/300
	16.43	55	1255	7.5	10	0.96	1.27	42/350 - 38/300
	18.60	48	2084	11	15	0.96	0.95	42/350 - 38/300
	20.96	43	1601	7.5	10	0.96	1.17	42/350 - 38/300
	25.52	35	1430	5.5	7.5	0.96	1.27	42/350 - 38/300
	28.90	31	1619	5.5	7.5	0.96	0.99	42/350 - 38/300

DIMENSIONI D'INGOMBRO

OVERALL DIMENSIONS

ALLGEMEINE ABMESSUNGEN

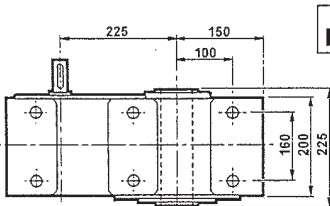
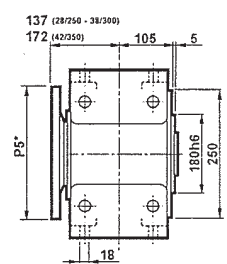
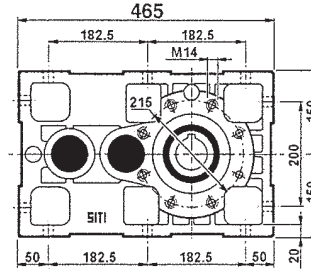
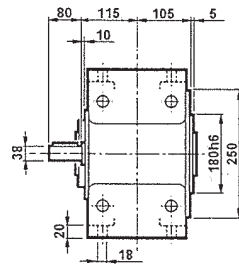
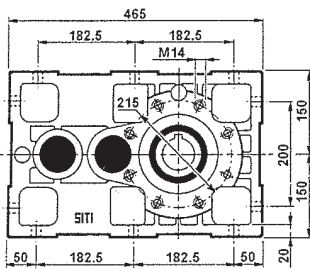

kg = 85

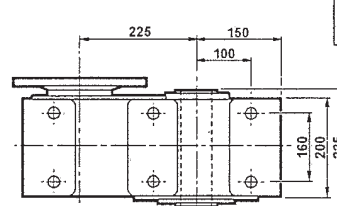
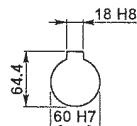

kg = 87

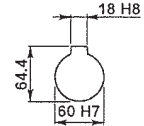

PL 125

MPL 125

P₅* : Vedere i PAM per ogni singola versione

P₅* : See PAM size for each single version

P₅* : Siehe PAM Größe für jede Ausführung

CARICHI RADIALI (N)

OVERHUNG LOADS (N)

RADIALE BELASTUNGEN (N)

ALBERO VELOCE / INPUT SHAFT / EINGANGSWELLE		
1400 min ⁻¹	PL 125	PL 125/3
	2100	1600

ALBERO LENTO / OUTPUT SHAFT / ABTRIEBSWELLE							
PL 125 - PL 125/3							
min ⁻¹	0°	30°	60°	90°	120°	150°	180°
20	18837	19474	21133	23681	26607	28896	29799
40	14245	14889	16415	18963	21896	24310	25211
60	12096	12604	14133	16678	19607	22022	23041
80	10567	11078	12604	15152	18081	20626	21515
100	9548	10059	11456	13993	16926	19439	20496
120	8782	9167	10693	13115	16170	18715	19733
140	8148	8505	9921	12168	15003	17364	18309
160	7637	7972	9299	11405	14063	16275	17161

Rotazione oraria
Clockwise
rotation
Uhrzeigersinn

Rotazione antioraria
Anticlockwise
rotation
Gegenuhrzeigersinn

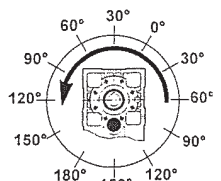
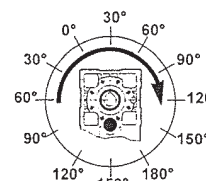

PL 125/3

PRESTAZIONI

PERFORMANCES

LEISTUNG

MPL 125/3

n ₁	i	n ₂	M ₂ (Nm)	kW ₁	HP ₁	RD
2800	26.47	106	1890	22.8	30.9	0.92
	30.32	92	1395	14.7	19.9	0.92
	34.08	82	1800	16.8	22.9	0.92
	38.46	73	1656	13.7	18.7	0.92
	41.49	67	1620	12.4	16.9	0.92
	47.25	59	1395	9.4	12.8	0.92
	53.11	53	1818	10.9	14.8	0.92
	59.60	47	1890	10.1	13.7	0.92
	64.66	43	1638	8.1	11.0	0.92
	73.22	38	1395	6.1	8.3	0.92
	93.42	30	1665	5.7	7.7	0.92
	105.79	26	1395	4.2	5.7	0.92

n ₁	i	n ₂	M ₂ (Nm)	kW ₁	HP ₁	RD	f _s	P.A.M.
2800	26.47	106	914	11	15	0.92	2.07	38/300
	30.32	92	1047	11	15	0.92	1.33	38/300
	34.08	82	1176	11	15	0.92	1.53	38/300
	38.46	73	664	5.5	7.5	0.92	2.49	19/200
	41.49	67	1432	11	15	0.92	1.13	38/300
	47.25	59	815	5.5	7.5	0.92	1.71	28/250
	53.11	53	917	5.5	7.5	0.92	1.98	28/250
	59.60	47	1029	5.5	7.5	0.92	1.84	19/200
	64.66	43	1116	5.5	7.5	0.92	1.47	28/250
	73.22	38	1264	5.5	7.5	0.92	1.10	28/250
	93.42	30	1612	5.5	7.5	0.92	1.03	19/200
	105.79	26	1328	4	7.5	0.92	1.05	19/200

1400	26.47	53	2100	12.6	17.2	0.92
	30.32	46	1550	8.1	11.1	0.92
	34.08	41	2000	9.4	12.7	0.92
	38.46	36	1840	7.6	10.4	0.92
	41.49	34	1800	6.9	9.4	0.92
	47.25	30	1550	5.2	7.1	0.92
	53.11	26	2020	6.1	8.2	0.92
	59.60	23	2100	5.6	7.6	0.92
	64.66	22	1820	4.5	6.1	0.92
	73.22	19	1550	3.4	4.6	0.92
	93.42	15	1850	3.2	4.3	0.92
	105.79	13	1550	2.3	3.2	0.92

1400	26.47	53	1827	11	15	0.92	1.15	38/300
	30.32	46	1751	9.2	12.5	0.92	0.89	38/300
	34.08	41	1968	9.2	12.5	0.92	1.02	38/300
	38.46	36	965	4	5.5	0.92	1.91	19/200
	41.49	34	1432	5.5	7.5	0.92	1.26	38/300
	47.25	30	1188	4	5.5	0.92	1.31	28/250
	53.11	26	1333	4	5.5	0.92	1.52	28/250
	59.60	23	1496	4	5.5	0.92	1.40	19/200
	64.66	22	1623	4	5.5	0.92	1.12	28/250
	73.22	19	1379	3	4	0.92	1.12	28/250
	93.42	15	1759	3	4	0.92	1.05	19/200
	105.79	13	1461	2.2	3	0.92	1.06	19/200

900	26.47	34	2310	8.9	12.2	0.92
	30.32	30	1705	5.8	7.8	0.92
	34.08	26	2200	6.6	9.0	0.92
	38.46	23	2024	5.4	7.3	0.92
	41.49	22	1980	4.9	6.6	0.92
	47.25	19	1705	3.7	5.0	0.92
	53.11	17	2222	4.3	5.8	0.92
	59.60	15	2310	4.0	5.4	0.92
	64.66	14	2002	3.2	4.3	0.92
	73.22	12	1705	2.4	3.2	0.92
	93.42	10	2035	2.2	3.0	0.92
	105.79	9	1705	1.7	2.2	0.92

900	26.47	34	1421	5.5	7.5	0.92	1.63	38/300
	30.32	30	1628	5.5	7.5	0.92	1.05	38/300
	34.08	26	1830	5.5	7.5	0.92	1.20	38/300
	38.46	23	826	2.2	3	0.92	2.45	19/200
	41.49	22	1620	4	5.5	0.92	1.22	38/300
	47.25	19	1015	2.2	3	0.92	1.68	28/250
	53.11	17	1141	2.2	3	0.92	1.95	28/250
	59.60	15	1280	2.2	3	0.92	1.80	19/200
	64.66	14	1389	2.2	3	0.92	1.44	28/250
	73.22	12	1573	2.2	3	0.92	1.08	28/250
	93.42	10	2006	2.2	3	0.92	1.01	19/200
	105.79	9	1549	1.5	2	0.92	1.10	19/200

DIMENSIONI D'INGOMBRO

OVERALL DIMENSIONS

ALLGEMEINE ABMESSUNGEN

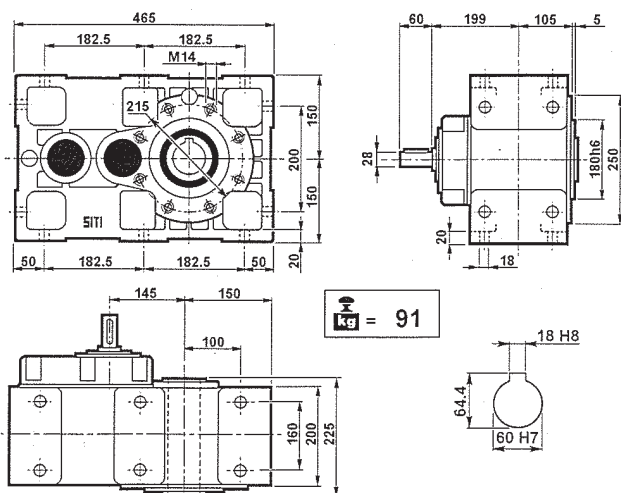

PL 125/3

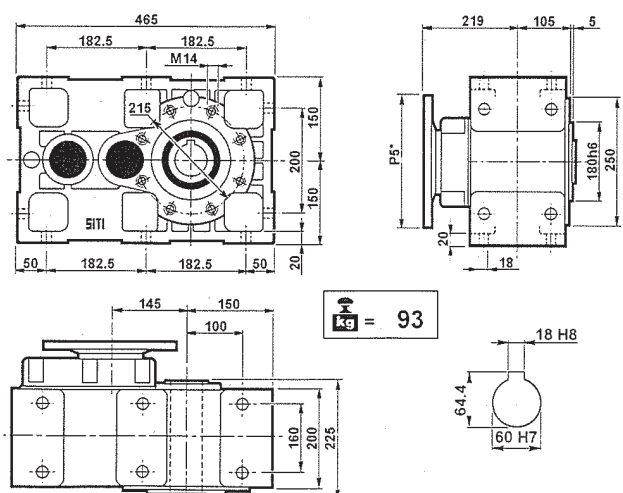

MPL 125/3

P₅* : Vedere i PAM per ogni singola versione
P₅* : See PAM size for each single version
P₅* : Siehe PAM Grösse für jede Ausführung

PL 160

PRESTAZIONI

PERFORMANCES

LEISTUNG

MPL 160

n ₁	i	n ₂	M ₂ (Nm)	kW ₁	HP ₁	RD
2800	9.87	284	2700	83.5	113.6	0.96
	12.74	220	2880	69.0	93.9	0.96
	15.54	180	2880	56.6	77.0	0.96
	16.27	172	3150	59.1	80.4	0.96
	19.87	141	2610	40.1	54.6	0.96
	21.01	133	3150	45.8	62.3	0.96
	25.62	109	2880	34.3	46.7	0.96
	32.75	85	2700	25.2	34.2	0.96

n ₁	i	n ₂	M ₂ (Nm)	kW ₁	HP ₁	RD	fs	P.A.M.
2800	9.87	284	808	25	34	0.96	3.34	48/350 - 42/350
	12.74	220	1043	25	34	0.96	2.76	48/350 - 42/350
	15.54	180	1272	25	34	0.96	2.26	48/350 - 42/350
	16.27	172	1332	25	34	0.96	2.37	48/350 - 42/350
	19.87	141	1627	25	34	0.96	1.60	48/350 - 42/350
	21.01	133	1720	25	34	0.96	1.83	48/350 - 42/350
	25.62	109	2097	25	34	0.96	1.37	48/350 - 42/350
	32.75	85	2681	25	34	0.96	1.01	48/350 - 42/350

n ₁	i	n ₂	M ₂ (Nm)	kW ₁	HP ₁	RD
1400	9.87	142	3000	46.4	63.1	0.96
	12.74	110	3200	38.4	52.2	0.96
	15.54	90	3200	31.4	42.8	0.96
	16.27	86	3500	32.8	44.7	0.96
	19.87	70	2900	22.3	30.3	0.96
	21.01	67	3500	25.4	34.6	0.96
	25.62	55	3200	19.1	25.9	0.96
	32.75	43	3000	14.0	19.0	0.96

n ₁	i	n ₂	M ₂ (Nm)	kW ₁	HP ₁	RD	fs	P.A.M.
1400	9.87	142	1422	22	30	0.96	2.11	48/350 - 42/350
	12.74	110	1835	22	30	0.96	1.74	48/350 - 42/350
	15.54	90	2239	22	30	0.96	1.43	48/350 - 42/350
	16.27	86	2344	22	30	0.96	1.49	48/350 - 42/350
	19.87	70	2863	22	30	0.96	1.01	48/350 - 42/350
	21.01	87	3027	22	30	0.96	1.16	48/350 - 42/350
	25.62	55	3104	18.5	25	0.96	1.03	48/350 - 42/350
	32.75	43	3217	15	20	0.96	0.93	48/350 - 42/350

n ₁	i	n ₂	M ₂ (Nm)	kW ₁	HP ₁	RD
900	9.87	91	3300	32.8	44.6	0.96
	12.74	71	3520	27.1	36.9	0.96
	15.54	58	3520	22.2	30.2	0.96
	16.27	55	3850	23.2	31.6	0.96
	19.87	45	3190	15.8	21.4	0.96
	21.01	43	3850	18.0	24.5	0.96
	25.62	35	3520	13.5	18.3	0.96
	32.75	27	3300	9.9	13.5	0.96

n ₁	i	n ₂	M ₂ (Nm)	kW ₁	HP ₁	RD	fs	P.A.M.
900	9.87	91	1508	15	20	0.96	2.19	48/350 - 42/350
	12.74	71	1947	15	20	0.96	1.81	48/350 - 42/350
	15.54	58	2375	15	20	0.96	1.48	48/350 - 42/350
	16.27	55	2486	15	20	0.96	1.55	48/350 - 42/350
	19.87	45	3036	15	20	0.96	1.05	48/350 - 42/350
	21.01	43	3210	15	20	0.96	1.20	48/350 - 42/350
	25.62	35	2871	11	15	0.96	1.23	48/350 - 42/350
	32.75	27	2502	7.5	10	0.96	1.32	48/350 - 42/350

DIMENSIONI D'INGOMBRO

OVERALL DIMENSIONS

ALLGEMEINE ABMESSUNGEN

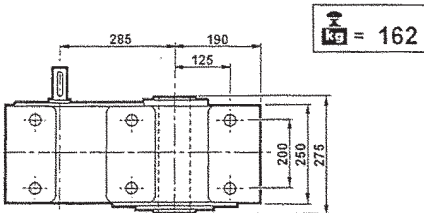
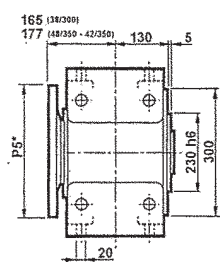
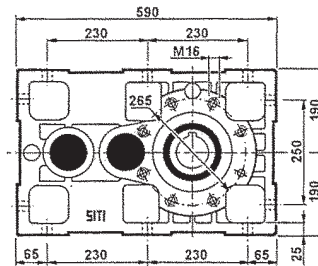
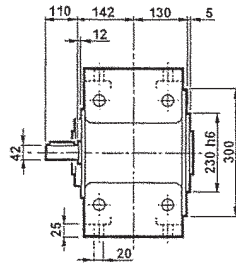
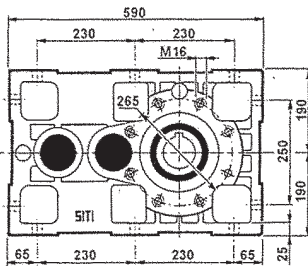

kg = 162

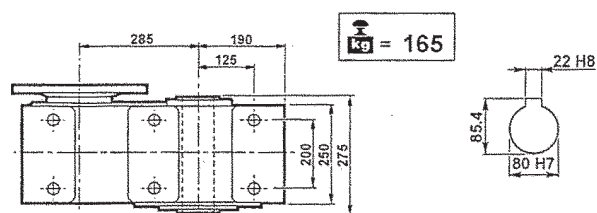

kg = 165

PL 160

MPL 160

P₅* : Vedere i PAM per ogni singola versione
P₅* : See PAM size for each single version
P₅* : Siehe PAM Grösse für jede Ausführung

CARICHI RADIALI (N)

OVERHUNG LOADS (N)

RADIALE BELASTUNGEN (N)

ALBERO VELOCE / INPUT SHAFT / EINGANGSWELLE		
1400 min ⁻¹	PL 160	PL 160/3
	3200	2300

ALBERO LENTO / OUTPUT SHAFT / ABTRIEBSWELLE							
PL 160- PL 160/3							
min ⁻¹	0°	30°	60°	90°	120°	150°	180°
20	26910	27820	30190	33830	38010	41280	42570
40	20350	21270	23450	27090	31280	34729	36015
60	17280	18005	20190	23825	28010	31460	32915
80	15095	15825	18005	21645	25830	29465	30735
100	13640	14370	16365	19990	24180	27770	29280
120	12545	13095	15275	18735	23100	26735	28190
140	11640	12150	14173	17383	21434	24806	26156
160	10910	11388	13284	16293	20089	23251	24516

Rotazione oraria
Clockwise
rotation
Uhrzeigersinn

Rotazione antioraria
Anticlockwise
rotation
Gegenuhrzeigersinn

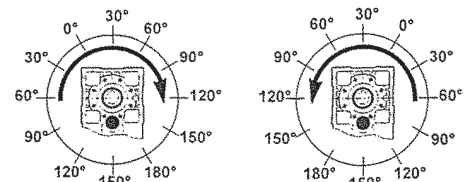

PL 160/3

PRESTAZIONI

PERFORMANCES

LEISTUNG

MPL 160/3

n ₁	i	n ₂	M ₂ (Nm)	kW ₁	HP ₁	RD
2800	34.24	82	3240	30.2	41.0	0.92
	39.47	71	2988	24.1	32.8	0.92
	41.78	67	3240	24.7	33.6	0.92
	50.46	55	2880	18.2	24.7	0.92
	53.36	52	3258	19.5	26.5	0.92
	58.57	48	3015	16.4	22.3	0.92
	65.07	43	3258	16.0	21.7	0.92
	71.52	39	2880	12.8	17.5	0.92
	75.63	37	3285	13.8	18.8	0.92
	83.19	34	2880	11.0	15.0	0.92
	92.23	30	3285	11.4	15.4	0.92
117.9	24	2880	7.8	10.6	0.92	

n ₁	i	n ₂	M ₂ (Nm)	kW ₁	HP ₁	RD	fs	P.A.M.
2800	34.24	82	2686	25	34	0.92	1.21	48/350 - 42/350
	39.47	71	1362	11	15	0.92	2.19	38/300
	41.78	67	3276	25	34	0.92	0.99	48/350 - 42/350
	50.46	55	1742	11	15	0.92	1.65	38/300
	53.36	52	1842	11	15	0.92	1.77	38/300
	58.57	48	1011	5.5	7.5	0.92	2.98	28/250
	65.07	43	2246	11	15	0.92	1.45	38/300
	71.52	39	1234	5.5	7.5	0.92	2.33	28/250
	75.63	37	1305	5.5	7.5	0.92	2.52	28/250
	83.19	34	2871	11	15	0.92	1.00	38/300
	92.23	30	1592	5.5	7.5	0.92	2.06	28/250
117.9	24	2035	5.5	7.5	0.92	1.42	28/250	

n ₁	i	n ₂	M ₂ (Nm)	kW ₁	HP ₁	RD
1400	34.24	41	3600	16.8	22.8	0.92
	39.47	35	3320	13.4	18.2	0.92
	41.78	34	3600	13.7	18.7	0.92
	50.46	28	3200	10.1	13.7	0.92
	53.36	26	3620	10.8	14.7	0.92
	58.57	24	3350	9.1	12.4	0.92
	65.07	22	3620	8.9	12.1	0.92
	71.52	20	3200	7.1	9.7	0.92
	75.63	19	3650	7.7	10.5	0.92
	83.19	17	3200	6.1	8.3	0.92
	92.23	15	3650	6.3	8.6	0.92
117.9	12	3200	4.3	5.9	0.92	

n ₁	i	n ₂	M ₂ (Nm)	kW ₁	HP ₁	RD	fs	P.A.M.
1400	34.24	41	3223	10	20	0.92	1.12	48/350 - 42/350
	39.47	35	2725	11	15	0.92	1.22	38/300
	41.78	34	3931	15	20	0.92	0.92	48/350 - 42/350
	50.46	28	2913	9.2	12.5	0.92	1.10	38/300
	53.36	26	3081	9.2	12.5	0.92	1.18	38/300
	58.57	24	1470	4	5.5	0.92	2.28	28/250
	65.07	22	3063	7.5	10	0.92	1.18	38/300
	71.52	20	1795	4	5.5	0.92	1.78	28/250
	75.63	19	1899	4	5.5	0.92	1.92	28/250
	83.19	17	2871	5.5	7.5	0.92	1.11	38/300
	92.23	15	2315	4	5.5	0.92	1.58	28/250
117.9	12	2960	4	5.5	0.92	1.08	28/250	

n ₁	i	n ₂	M ₂ (Nm)	kW ₁	HP ₁	RD
900	34.24	26	3960	11.8	16.1	0.92
	39.47	23	3652	9.5	12.9	0.92
	41.78	22	3960	9.7	13.2	0.92
	50.46	18	3520	7.1	9.7	0.92
	53.36	17	3982	7.6	10.4	0.92
	58.57	15	3685	6.4	8.8	0.92
	65.07	14	3982	6.3	8.5	0.92
	71.52	13	3520	5.0	6.9	0.92
	75.63	12	4015	5.4	7.4	0.92
	83.19	11	3520	4.3	5.9	0.92
	92.23	10	4015	4.5	6.1	0.92
117.9	8	3520	3.1	4.2	0.92	

n ₁	i	n ₂	M ₂ (Nm)	kW ₁	HP ₁	RD	fs	P.A.M.
900	34.24	26	3677	11	15	0.92	1.08	48/350 - 42/350
	39.47	23	2119	5.5	7.5	0.92	1.72	38/300
	41.78	22	3058	7.5	10	0.92	1.30	48/350 - 42/350
	50.46	18	2709	5.5	7.5	0.92	1.30	38/300
	53.36	17	2865	5.5	7.5	0.92	1.39	38/300
	58.57	15	1258	2.2	3	0.92	2.93	28/250
	65.07	14	3494	5.5	7.5	0.92	1.14	38/300
	71.52	13	1536	2.2	3	0.92	2.29	28/250
	75.63	12	1624	2.2	3	0.92	2.47	28/250
	83.19	11	3248	4	5.5	0.92	1.08	38/300
	92.23	10	1981	2.2	3	0.92	2.03	28/250
117.9	8	2532	2.2	3	0.92	1.39	28/250	

DIMENSIONI D'INGOMBRO

OVERALL DIMENSIONS

ALLGEMEINE ABMESSUNGEN

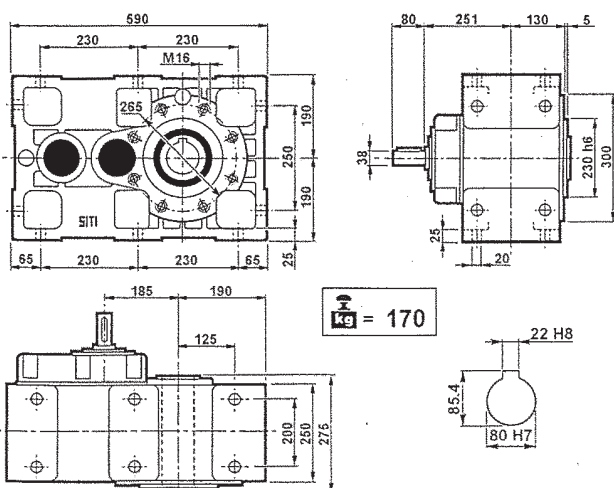

PL 160/3

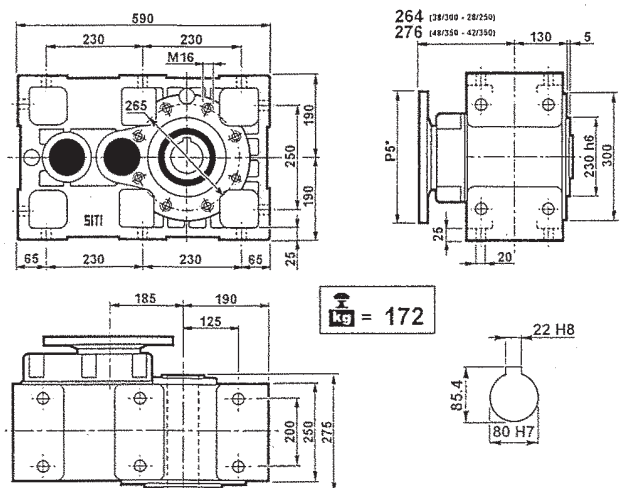

MPL 160/3

P₅* : Vedere i PAM per ogni singola versione
P₅* : See PAM size for each single version
P₅* : Siehe PAM Grösse für jede Ausführung

PRESTAZIONI
PERFORMANCES
LEISTUNG

PD..
PD../3

	Pag. Page <i>Seite</i>
PD 63, MPD 63	42
PD 63/3, MPD 63/3	43
PD 80, MPD 80	44
PD 80/3, MPD 80/3	45
PD 100, MPD 100	46
PD 100/3, MPD 100/3	47
PD 125, MPD 125	48
PD 125/3, MPD 125/3	49
PD 160, MPD 160	50
PD 160/3, MPD 160/3	51

PD 63

PRESTAZIONI

PERFORMANCES

LEISTUNG

MPD 63

n ₁	i	n ₂	M ₂ (Nm)	kW ₁	HP ₁	RD
2800	10.60	264	180	5.2	7.1	0.96
	13.65	205	180	4.0	5.5	0.96
	15.01	187	180	3.7	5.0	0.96
	17.97	156	216	3.7	5.0	0.96
	18.71	150	153	2.5	3.4	0.96
	23.12	121	207	2.7	3.7	0.96
	25.42	110	207	2.5	3.4	0.96
31.69	88	162	1.6	2.1	0.96	

n ₁	i	n ₂	M ₂ (Nm)	kW ₁	HP ₁	RD	fs	P.A.M.
2800	10.60	264	76	2.2	3	0.96	2.36	24/200 - 19/200
	13.65	205	98	2.2	3	0.96	1.83	24/200 - 19/200
	15.01	187	108	2.2	3	0.96	1.66	24/200 - 19/200
	17.97	156	129	2.2	3	0.96	1.67	24/200 - 19/200
	18.71	150	135	2.2	3	0.96	1.14	24/200 - 19/200
	23.12	121	167	2.2	3	0.96	1.24	24/200 - 19/200
	25.42	110	125	1.5	2	0.96	1.66	24/200 - 19/200
31.69	88	156	1.5	2	0.96	1.04	24/200 - 19/200	

n ₁	i	n ₂	M ₂ (Nm)	kW ₁	HP ₁	RD
1400	10.60	132	200	2.9	3.9	0.96
	13.65	103	200	2.2	3.0	0.96
	15.01	93	200	2.0	2.8	0.96
	17.97	78	240	2.0	2.8	0.96
	18.71	75	170	1.4	1.9	0.96
	23.12	61	230	1.5	2.1	0.96
	25.42	55	230	1.4	1.9	0.96
31.69	44	180	0.9	1.2	0.96	

n ₁	i	n ₂	M ₂ (Nm)	kW ₁	HP ₁	RD	fs	P.A.M.
1400	10.60	132	125	1.8	2.5	0.96	1.60	24/200 - 19/200
	13.65	103	161	1.8	2.5	0.96	1.24	24/200 - 19/200
	15.01	93	177	1.8	2.5	0.96	1.13	24/200 - 19/200
	17.97	78	212	1.8	2.5	0.96	1.13	24/200 - 19/200
	18.71	75	184	1.5	2.0	0.96	0.92	24/200 - 19/200
	23.12	61	227	1.5	2.0	0.96	1.01	24/200 - 19/200
	25.42	55	183	1.1	1.5	0.96	1.26	24/200 - 19/200
31.69	44	156	0.75	1.0	0.96	1.16	24/200 - 19/200	

n ₁	i	n ₂	M ₂ (Nm)	kW ₁	HP ₁	RD
900	10.60	85	220	2.0	2.8	0.96
	13.65	66	220	1.6	2.2	0.96
	15.01	60	220	1.4	2.0	0.96
	17.97	50	264	1.4	2.0	0.96
	18.71	48	187	1.0	1.3	0.96
	23.12	39	253	1.1	1.5	0.96
	25.42	35	253	1.0	1.3	0.96
31.69	28	198	0.6	0.8	0.96	

n ₁	i	n ₂	M ₂ (Nm)	kW ₁	HP ₁	RD	fs	P.A.M.
900	10.60	85	119	1.1	1.5	0.96	1.85	24/200 - 19/200
	13.65	66	153	1.1	1.5	0.96	1.44	24/200 - 19/200
	15.01	60	168	1.1	1.5	0.96	1.31	24/200 - 19/200
	17.97	50	201	1.1	1.5	0.96	1.31	24/200 - 19/200
	18.71	48	210	1.1	1.5	0.96	0.89	24/200 - 19/200
	23.12	40	259	1.1	1.5	0.96	0.98	24/200 - 19/200
	25.42	35	194	0.75	1.0	0.96	1.30	24/200 - 19/200
31.69	28	178	0.55	0.75	0.96	1.12	24/200 - 19/200	

DIMENSIONI D'INGOMBRO

OVERALL DIMENSIONS

ALLGEMEINE ABMESSUNGEN

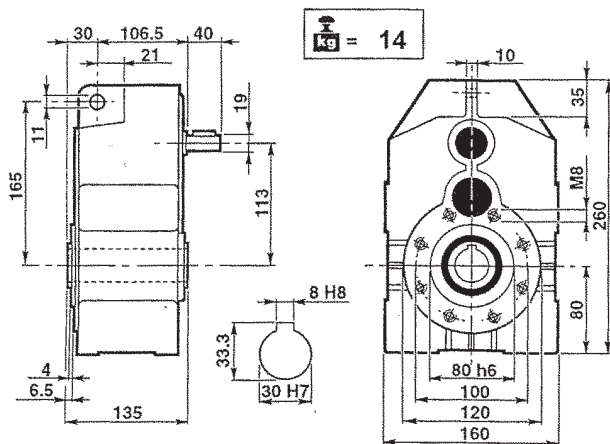

PD 63

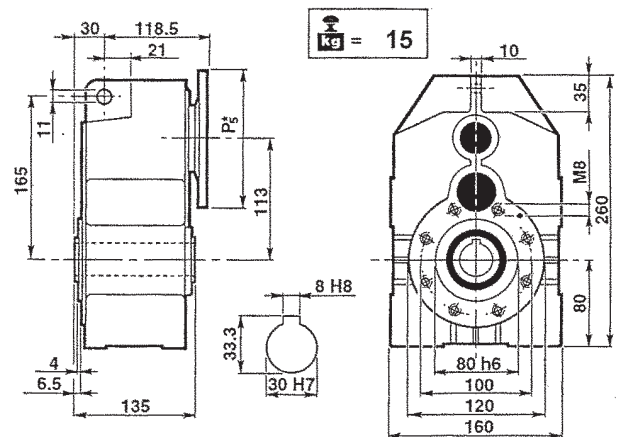

MPD 63

P₅* : Vedere i PAM per ogni singola versione

P₅* : See PAM size for each single version

P₅* : Siehe PAM Grösse für jede Ausführung

CARICHI RADIALI (N)

OVERHUNG LOADS (N)

RADIALE BELASTUNGEN (N)

ALBERO VELOCE / INPUT SHAFT / EINGANGSWELLE		
1400 min ⁻¹	PD 63	PD 63/3
	650	400

ALBERO LENTO / OUTPUT SHAFT / ABTRIEBSWELLE								
PD 63 - PD 63/3								
min ⁻¹	0°	30°	60°	90°	120°	150°	180°	
20	9205	9517	10327	11572	13002	14121	14562	
40	6961	7276	8022	9267	10700	11880	12320	
60	5911	6159	6907	8150	9582	10762	11259	
80	5164	5413	6159	7404	8836	10079	10514	
100	4666	4916	5598	6838	8271	9500	10016	
120	4291	4480	5225	6409	7902	9145	9643	
140	3982	4156	4848	5946	7332	8486	8948	
160	3732	3896	4544	5574	6872	7954	8386	

Rotazione oraria
Clockwise
rotation
Uhrzeigersinn

Rotazione antioraria
Anticlockwise
rotation
Gegenuhrzeigersinn

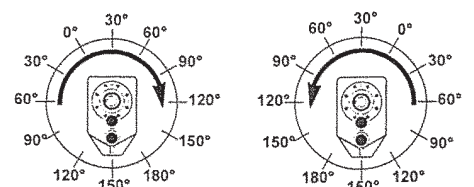

PD 63/3

PRESTAZIONI

PERFORMANCES

LEISTUNG

MPD 63/3

n_1	i	n_2	M_2 (Nm)	kW_1	HP_1	RD
2800	29.25	96	252	2.7	3.7	0.92
	37.68	74	270	2.3	3.1	0.92
	41.43	68	252	1.9	2.6	0.92
	47.53	59	180	1.2	1.6	0.92
	51.66	54	198	1.2	1.7	0.92
	58.72	48	270	1.5	2.0	0.92
	64.55	43	252	1.2	1.7	0.92
	67.37	42	198	0.9	1.3	0.92
	80.5	35	198	0.8	1.1	0.92
	83.22	34	270	1.0	1.4	0.92
	91.49	31	252	0.9	1.2	0.92
	114.09	25	198	0.6	0.8	0.92

n_1	i	n_2	M_2 (Nm)	kW_1	HP_1	RD	f_s	P.A.M.
2800	29.25	96	138	1.50	2	0.92	1.83	19/200 - 14/160
	37.68	74	177	1.50	2	0.92	1.52	19/200 - 14/160
	41.43	66	195	1.50	2	0.92	1.29	19/200 - 14/160
	47.53	59	112	0.75	1	0.92	1.61	14/160
	51.66	54	178	1.10	1.5	0.92	1.11	19/200 - 14/160
	58.72	48	138	0.75	1	0.92	1.95	14/160
	64.55	43	152	0.75	1	0.92	1.66	14/160
	67.37	42	53	0.25	0.34	0.92	3.75	11/140
	80.5	35	189	0.75	1	0.92	1.05	14/160
	83.22	34	65	0.25	0.34	0.92	4.14	11/140
	91.49	31	72	0.25	0.34	0.92	3.51	11/140
	114.09	25	89	0.25	0.34	0.92	2.21	11/140

1400	29.25	48	280	1.5	2.1	0.92
	37.68	37	300	1.3	1.7	0.92
	41.43	34	280	1.1	1.5	0.92
	47.53	29	200	0.7	0.9	0.92
	51.66	27	220	0.7	0.9	0.92
	58.72	24	300	0.8	1.1	0.92
	64.55	22	280	0.7	0.9	0.92
	67.37	21	220	0.5	0.7	0.92
	80.5	17	220	0.4	0.6	0.92
	83.22	17	300	0.6	0.8	0.92
	91.49	15	280	0.5	0.7	0.92
	114.09	12	220	0.3	0.4	0.92

1400	29.25	48	138	0.75	1	0.92	2.03	19/200 - 14/160
	37.68	37	177	0.75	1	0.92	1.69	19/200 - 14/160
	41.43	34	195	0.75	1	0.92	1.44	19/200 - 14/160
	47.53	29	110	0.37	0.5	0.92	1.81	14/160
	51.66	27	243	0.75	1	0.92	0.90	19/200 - 14/160
	58.72	24	136	0.37	0.5	0.92	2.20	14/160
	64.55	22	150	0.37	0.5	0.92	1.87	14/160
	67.37	21	76	0.18	0.25	0.92	2.89	11/140
	80.5	17	187	0.37	0.50	0.92	1.18	14/160
	83.22	17	94	0.18	0.25	0.92	3.19	11/140
	91.49	15	103	0.18	0.25	0.92	2.71	11/140
	114.09	12	129	0.18	0.25	0.92	1.71	11/140

900	29.25	31	308	1.1	1.5	0.92
	37.68	24	330	0.9	1.2	0.92
	41.43	22	308	0.8	1.0	0.92
	47.53	19	220	0.5	0.6	0.92
	51.66	17	242	0.5	0.7	0.92
	58.72	15	330	0.6	0.8	0.92
	64.55	14	308	0.5	0.7	0.92
	67.37	13	242	0.4	0.5	0.92
	80.5	11	242	0.3	0.4	0.92
	83.22	11	330	0.4	0.6	0.92
	91.49	10	308	0.3	0.5	0.92
	114.09	8	242	0.2	0.3	0.92

900	29.25	31	157	0.55	0.75	0.92	1.96	19/200 - 14/160
	37.68	24	202	0.55	0.75	0.92	1.63	19/200 - 14/160
	41.43	22	222	0.55	0.75	0.92	1.38	19/200 - 14/160
	47.53	19	216	0.25	0.34	0.92	1.90	14/160
	51.66	17	277	0.55	0.75	0.92	0.87	19/200 - 14/160
	58.72	15	143	0.25	0.34	0.92	2.30	14/160
	64.55	14	158	0.25	0.34	0.92	1.96	14/160
	67.37	13	79	0.12	0.16	0.92	3.07	11/140
	80.5	11	196	0.25	0.34	0.92	1.23	14/160
	83.22	11	97	0.12	0.16	0.92	3.8	11/140
	91.49	10	107	0.12	0.16	0.92	2.87	11/140
	114.09	8	134	0.12	0.16	0.92	1.81	11/140

DIMENSIONI D'INGOMBRO

OVERALL DIMENSIONS

ALLGEMEINE ABMESSUNGEN

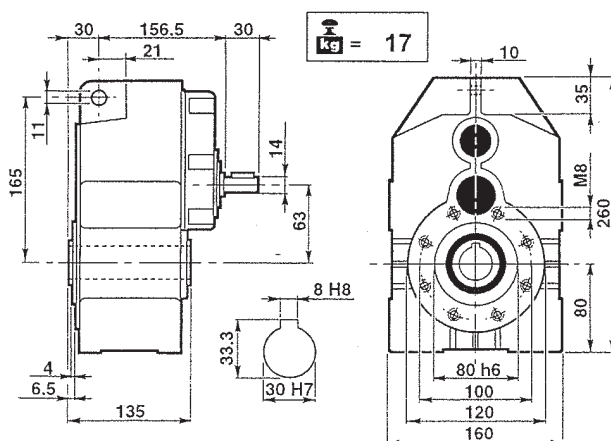

PD 63/3

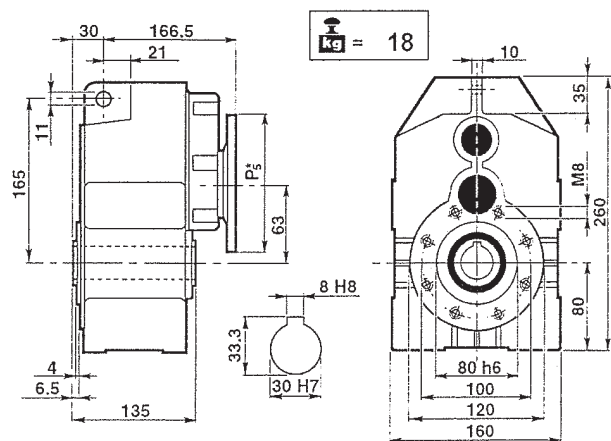

MPD 63/3

P_5^* : Vedere i PAM per ogni singola versione
 P_5^* : See PAM size for each single version
 P_5^* : Siehe PAM Größe für jede Ausführung

PD 80

PRESTAZIONI

PERFORMANCES

LEISTUNG

MPD 80

n ₁	i	n ₂	M ₂ (Nm)	kW ₁	HP ₁	RD
2800	10.02	279	360	11.0	14.9	0.96
	12.94	216	360	8.5	11.6	0.96
	15.78	177	360	7.0	9.5	0.96
	17.95	156	441	7.5	10.2	0.96
	20.17	139	405	6.1	8.3	0.96
	23.17	121	378	5.0	6.8	0.96
	28.26	99	378	4.1	5.6	0.96
36.13	77	360	3.0	4.1	0.96	
1400	10.02	140	400	6.1	8.3	0.96
	12.94	108	400	4.7	6.4	0.96
	15.78	89	400	3.9	5.3	0.96
	17.95	78	490	4.2	5.7	0.96
	20.17	69	450	3.4	4.6	0.96
	23.17	60	420	2.8	3.8	0.96
	28.26	50	420	2.3	3.1	0.96
36.13	39	400	1.7	2.3	0.96	
900	10.02	90	440	4.3	5.9	0.96
	12.94	70	440	3.3	4.5	0.96
	15.78	57	440	2.7	3.7	0.96
	17.95	50	539	2.9	4.0	0.96
	20.17	45	495	2.4	3.3	0.96
	23.17	39	462	2.0	2.7	0.96
	28.26	32	462	1.6	2.2	0.96
36.13	25	440	1.2	1.6	0.96	

n ₁	i	n ₂	M ₂ (Nm)	kW ₁	HP ₁	RD	fs	P.A.M.
2800	10.02	279	180	5.5	7.5	0.96	2.00	28/250 - 24/200
	12.94	216	233	5.5	7.5	0.96	1.54	28/250 - 24/200
	15.78	177	284	5.5	7.5	0.96	1.27	28/250 - 24/200
	17.95	156	323	5.5	7.5	0.96	1.36	28/250 - 24/200
	20.17	139	363	5.5	7.5	0.96	1.11	28/250 - 24/200
	23.17	121	303	4.0	5.5	0.96	1.25	28/250 - 24/200
	28.26	99	370	4.0	5.5	0.96	1.02	28/250 - 24/200
36.13	77	260	2.2	3.0	0.96	1.38	28/250 - 24/200	
1400	10.02	140	262	4.0	5.5	0.96	1.52	28/250 - 24/200
	12.94	108	339	4.0	5.5	0.96	1.18	28/250 - 24/200
	15.78	89	310	3.0	4.0	0.96	1.29	28/250 - 24/200
	17.95	78	470	4.0	5.5	0.96	1.04	28/250 - 24/200
	20.17	69	396	3.0	4	0.96	1.14	28/250 - 24/200
	23.17	60	334	2.2	3	0.96	1.26	28/250 - 24/200
	28.26	49	407	2.2	3	0.96	1.03	28/250 - 24/200
36.13	39	365	1.5	2	0.96	1.13	28/250 - 24/200	
900	10.02	90	225	2.2	3	0.96	1.96	28/250 - 24/200
	12.94	70	290	2.2	3	0.96	1.52	28/250 - 24/200
	15.78	57	354	2.2	3	0.96	1.24	28/250 - 24/200
	17.95	50	402	2.2	3	0.96	1.34	28/250 - 24/200
	20.17	45	452	2.2	3	0.96	1.10	28/250 - 24/200
	23.17	39	354	1.5	2	0.96	1.30	28/250 - 24/200
	28.26	32	432	1.5	2	0.96	1.07	28/250 - 24/200
36.13	25	405	1.1	1.5	0.96	1.09	28/250 - 24/200	

DIMENSIONI D'INGOMBRO

OVERALL DIMENSIONS

ALLGEMEINE ABMESSUNGEN

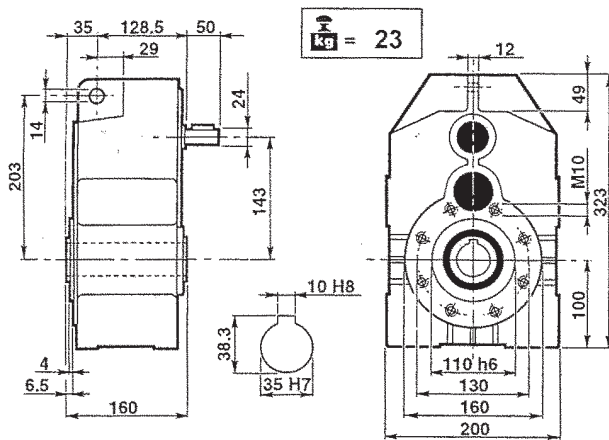

PD 80

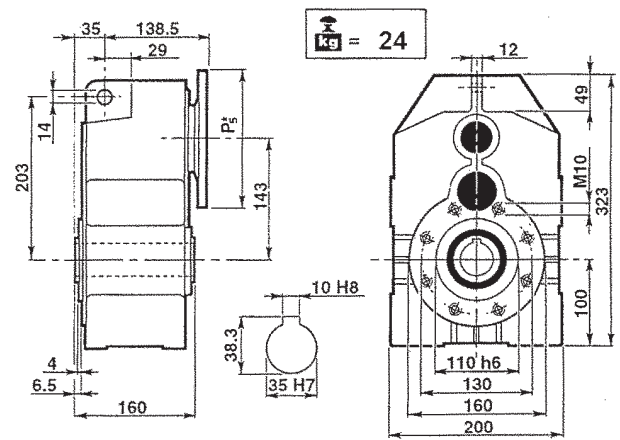

MPD 80

P₅* : Vedere i PAM per ogni singola versione

P₅* : See PAM size for each single version

P₅* : Siehe PAM Größe für jede Ausführung

CARICHI RADIALI (N)

OVERHUNG LOADS (N)

RADIALE BELASTUNGEN (N)

ALBERO VELOCE / INPUT SHAFT / EINGANGSWELLE		
1400 min ⁻¹	PD 80	PD 80/3
	900	650

ALBERO LENTO / OUTPUT SHAFT / ABTRIEBSWELLE								
PD 80 - PD 80/3								
min ⁻¹	0°	30°	60°	90°	120°	150°	180°	
20	9995	10333	11213	12565	14118	15332	15811	
40	7558	7900	8710	10062	11618	12899	13377	
60	6418	6687	7499	8849	10403	11685	12225	
80	5607	5878	6687	8039	9594	10944	11416	
100	5066	5337	6078	7425	8981	10314	10375	
120	4659	4864	5673	6959	8580	9930	10470	
140	4323	4513	5264	6457	7961	9214	9715	
160	4052	4230	4934	6052	7462	8636	9106	

Rotazione oraria
Clockwise
rotation
Uhrzeigersinn

Rotazione antioraria
Anticlockwise
rotation
Gegenuhrzeigersinn

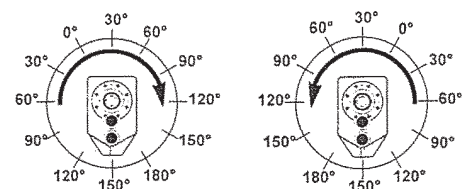

PD 80/3

PRESTAZIONI

PERFORMANCES

LEISTUNG

MPD 80/3

n ₁	i	n ₂	M ₂ (Nm)	kW ₁	HP ₁	RD
24.45	115	459	6.0	8.1	0.92	
31.57	89	459	4.6	6.3	0.92	
38.47	73	450	3.7	5.1	0.92	
46.91	60	432	2.9	4.0	0.92	
49.22	57	360	2.3	3.2	0.92	
56.54	50	459	2.6	3.5	0.92	
59.97	47	360	1.9	2.6	0.92	
68.95	41	441	2.0	2.8	0.92	
84.58	33	468	1.8	2.4	0.92	
88.15	32	378	1.4	1.9	0.92	
103.15	27	450	1.4	1.9	0.92	
131.86	21	378	0.9	1.2	0.92	

n ₁	i	n ₂	M ₂ (Nm)	kW ₁	HP ₁	RD		P.A.M.
24.45	115	169	2.2	3	0.92	2.72		24/200 - 19/200
31.57	89	218	2.2	3	0.92	2.11		24/200 - 19/200
38.47	73	362	3.0	4	0.92	1.24		28/250 - 24/200
46.91	60	442	3.0	4	0.92	0.98		28/250 - 24/200
49.22	57	340	2.2	3	0.92	1.06		24/200 - 19/200
56.54	50	390	2.2	3	0.92	1.18		24/200 - 19/200
59.97	47	282	1.5	2	0.92	1.28		28/250 - 24/200
68.95	41	325	1.5	2	0.92	1.36		24/200 - 19/200
84.58	33	199	0.75	1	0.92	2.35		14/160
88.15	32	304	1.1	1.5	0.92	1.24		24/200 - 19/200
103.15	27	243	0.75	1	0.92	1.85		14/160
131.86	21	310	0.75	1	0.92	1.22		14/160

24.45	57	510	3.3	4.5	0.92	
31.57	44	510	2.6	3.5	0.92	
38.47	36	500	2.1	2.8	0.92	
46.91	30	480	1.6	2.2	0.92	
49.22	28	400	1.3	1.8	0.92	
56.54	25	510	1.4	2.0	0.92	
59.97	23	400	1.1	1.4	0.92	
68.95	20	490	1.1	1.5	0.92	
84.58	17	520	1.0	1.3	0.92	
88.15	16	420	0.8	1.0	0.92	
103.15	14	500	0.8	1.1	0.92	
131.86	11	420	0.5	0.7	0.92	

24.45	57	276	1.8	2.5	0.92	1.85		24/200 - 19/200
31.57	44	357	1.8	2.5	0.92	1.43		24/200 - 19/200
38.47	36	531	2.2	3.0	0.92	0.94		28/250 - 24/200
46.91	30	442	1.5	2.0	0.92	1.09		28/250 - 24/200
49.22	28	340	1.1	1.5	0.92	1.18		24/200 - 19/200
56.54	25	390	1.1	1.5	0.92	1.31		24/200 - 19/200
59.97	23	414	1.1	1.5	0.92	0.97		28/250 - 24/200
68.95	20	476	1.1	1.5	0.92	1.03		24/200 - 19/200
84.58	17	196	0.37	0.5	0.92	2.65		14/160
88.15	16	415	0.75	1.0	0.92	1.01		24/200 - 19/200
103.15	14	240	0.37	0.5	0.92	2.09		14/160
131.86	11	306	0.37	0.5	0.92	1.37		14/160

24.45	37	561	2.4	3.2	0.92	
31.57	29	561	1.8	2.5	0.92	
38.47	23	550	1.5	2.0	0.92	
46.91	19	528	1.2	1.6	0.92	
49.22	18	440	0.9	1.2	0.92	
56.54	16	561	1.0	1.4	0.92	
59.97	15	440	0.8	1.0	0.92	
68.95	13	539	0.8	1.1	0.92	
84.58	11	572	0.7	0.9	0.92	
88.15	10	462	0.5	0.7	0.92	
103.15	9	550	0.5	0.7	0.92	
131.86	7	462	0.4	0.5	0.92	

24.45	37	263	1.1	1.5	0.92	2.14		24/200 - 19/200
31.57	29	339	1.1	1.5	0.92	1.65		24/200 - 19/200
38.47	23	563	1.5	2.0	0.92	0.98		28/250 - 24/200
46.91	19	504	1.1	1.5	0.92	1.05		28/250 - 24/200
49.22	18	360	0.75	1.0	0.92	1.22		24/200 - 19/200
56.54	16	414	0.75	1.0	0.92	1.36		24/200 - 19/200
59.97	15	439	0.75	1.0	0.92	1.00		28/250 - 24/200
68.95	13	505	0.75	1.0	0.92	1.07		24/200 - 19/200
84.58	11	206	0.25	0.34	0.92	2.77		14/160
88.15	10	473	0.55	0.75	0.92	0.89		24/200 - 19/200
103.15	9	252	0.25	0.34	0.92	2.18		14/160
131.86	7	322	0.25	0.34	0.92	1.44		14/160

DIMENSIONI D'INGOMBRO

OVERALL DIMENSIONS

ALLGEMEINE ABMESSUNGEN

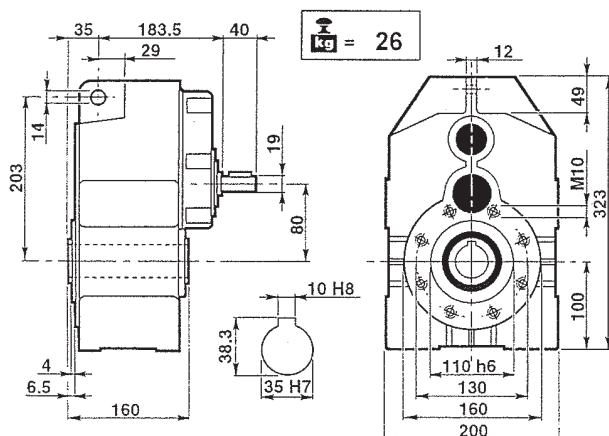

PD 80/3

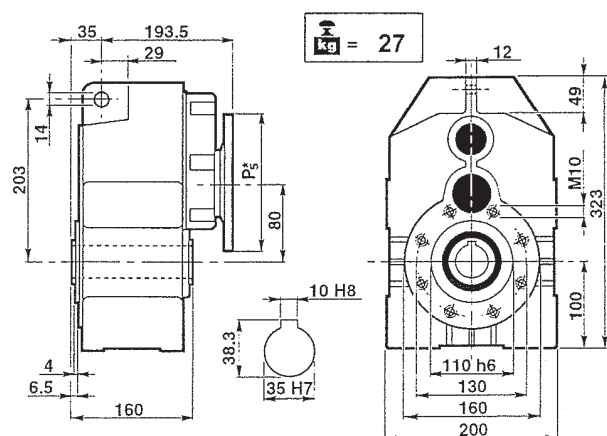

MPD 80/3

P₅* : Vedere i PAM per ogni singola versione
P₅* : See PAM size for each single version
P₅* : Siehe PAM Grösse für jede Ausführung

PD 100

PRESTAZIONI

	n ₁	i	n ₂	M ₂ (Nm)	kW ₁	HP ₁	RD
2800	9.98	281	720	22.0	30.0	0.96	
	12.89	217	720	17.1	23.2	0.96	
	15.47	181	855	16.9	23.0	0.96	
	15.72	178	720	14.0	19.0	0.96	
	19.98	140	810	12.4	16.8	0.96	
	20.49	137	675	10.1	13.7	0.96	
	24.36	115	810	10.2	13.8	0.96	
	31.75	88	675	6.5	8.8	0.96	
1400	9.98	140	800	12.2	16.6	0.96	
	12.89	109	800	9.5	12.9	0.96	
	15.47	90	950	9.4	12.8	0.96	
	15.72	89	800	7.8	10.6	0.96	
	19.98	70	900	6.9	9.4	0.96	
	20.49	68	750	5.6	7.6	0.96	
	24.36	57	900	5.6	7.7	0.96	
	31.75	44	750	3.6	4.9	0.96	
900	9.98	90	880	8.7	11.8	0.96	
	12.89	70	880	6.7	9.1	0.96	
	15.47	58	1045	6.6	9.0	0.96	
	15.72	57	880	5.5	7.5	0.96	
	19.98	45	990	4.9	6.6	0.96	
	20.49	44	825	4.0	5.4	0.96	
	24.36	37	990	4.0	5.4	0.96	
	31.75	28	825	2.6	3.5	0.96	

PERFORMANCES

LEISTUNG

MPD 100

	n ₁	i	n ₂	M ₂ (Nm)	kW ₁	HP ₁	RD	f _s	P.A.M.
2800	9.98	281	359	11	15	0.96	2.01		38/300 - 28/250
	12.89	217	464	11	15	0.96	1.55		38/300 - 28/250
	15.47	178	557	11	15	0.96	1.54		38/300 - 28/250
	15.72	137	566	11	15	0.96	1.27		38/300 - 28/250
	19.98	181	720	11	15	0.96	1.13		38/300 - 28/250
	20.49	140	604	9	12.5	0.96	1.12		38/300 - 28/250
	24.36	115	718	9	12.5	0.96	1.13		38/300 - 28/250
	31.75	88	672	5.5	7.5	0.96	1.18		38/300 - 28/250
1400	9.98	140	719	11	15	0.96	1.11		38/300 - 28/250
	12.89	109	777	9.2	12.5	0.96	1.03		38/300 - 28/250
	15.47	90	932	9.2	12.5	0.96	1.02		38/300 - 28/250
	15.72	89	772	7.5	10	0.96	1.04		38/300 - 28/250
	19.98	70	720	5.5	7.5	0.96	1.25		38/300 - 28/250
	20.49	68	738	5.5	7.5	0.96	1.02		38/300 - 28/250
	24.36	57	877	5.5	7.5	0.96	1.03		38/300 - 28/250
	31.75	44	624	3.0	4	0.96	1.20		38/300 - 28/250
900	9.98	90	559	5.5	7.5	0.96	1.57		38/300 - 28/250
	12.89	70	722	5.5	7.5	0.96	1.22		38/300 - 28/250
	15.47	58	667	5.5	7.5	0.96	1.21		38/300 - 28/250
	15.72	57	881	5.5	7.5	0.96	1.00		38/300 - 28/250
	19.98	45	814	4.0	5.5	0.96	1.22		38/300 - 28/250
	20.49	44	835	4.0	5.5	0.96	0.99		38/300 - 28/250
	24.36	37	923	4.0	5.5	0.96	1.00		38/300 - 28/250
	31.75	28	712	2.2	3.0	0.96	1.16		38/300 - 28/250

DIMENSIONI D'INGOMBRO

OVERALL DIMENSIONS

ALLGEMEINE ABMESSUNGEN

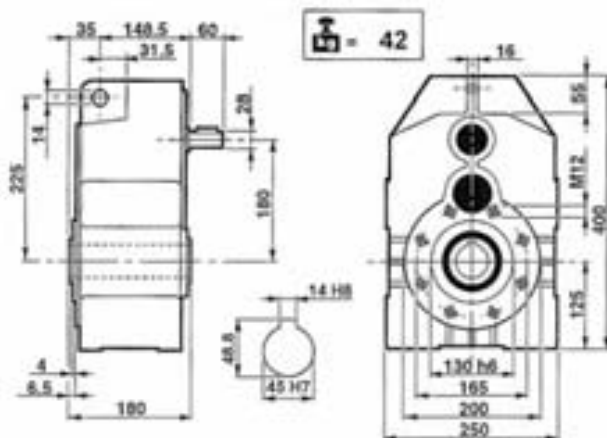

PD 100

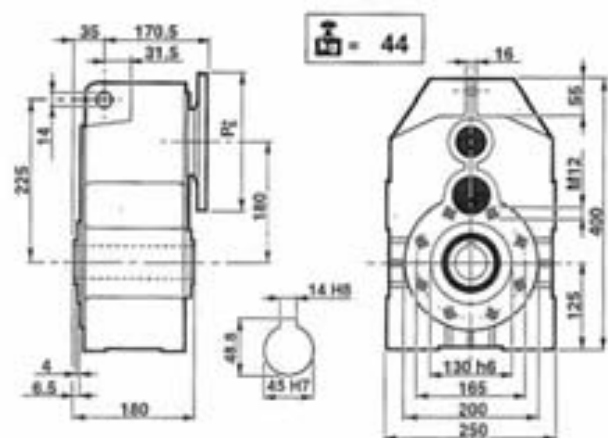

MPD 100

Ps* : Vedere i PAM per ogni singola versione
 Ps* : See PAM size for each single version
 Ps* : Siehe PAM Größe für jede Ausführung

CARICHI RADIALI (N)

OVERHUNG LOADS (N)

RADIALE BELASTUNGEN (N)

ALBERO VELOCE / INPUT SHAFT / EINGANGSWELLE							
1400 min ⁻¹	PD 100	PD 100/3					
	1400	1000					
ALBERO LENTO / OUTPUT SHAFT / ABTRIEBSWELLE							
PD 100 - PD 100/3							
min ⁻¹	0°	30°	60°	90°	120°	150°	180°
20	13186	13632	14793	16577	18625	20227	20859
40	9972	10422	11491	13274	15327	17017	17646
60	8467	8822	9893	11674	13725	15415	16128
80	7397	7754	8822	10606	12657	14438	15060
100	6684	7041	8019	9795	11848	13607	14347
120	6147	6417	7485	9180	11319	13100	13813
140	5704	5954	6945	8518	10502	12155	12817
160	5346	5580	6509	7984	9844	11393	12013

Rotazione oraria
 Clockwise
 rotation
 Uhrzeigersinn

Rotazione antioraria
 Anticlockwise
 rotation
 Gegenuhrzeigersinn

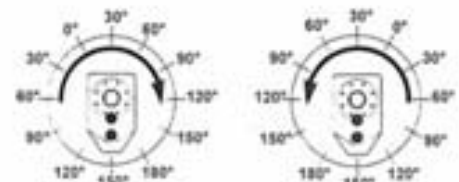

PD 100/3

PRESTAZIONI

PERFORMANCES

LEISTUNG

MPD 100/3

n ₁	i	n ₂	M ₂ (Nm)	kW ₁	HP ₁	RD
2800	21.40	131	810	12.1	16.4	0.92
	25.68	109	900	11.2	15.2	0.92
	33.16	84	882	8.5	11.5	0.92
	37.74	74	918	7.8	10.5	0.92
	40.44	69	882	7.0	9.5	0.92
	48.74	57	900	5.9	8.0	0.92
	52.70	53	720	4.4	5.9	0.92
	59.44	47	900	4.8	6.6	0.92
	72.91	38	918	4.0	5.5	0.92
	77.47	36	720	3.0	4.0	0.92
	88.91	31	918	3.3	4.5	0.92
	115.88	24	720	2.0	2.7	0.92

n ₁	i	n ₂	M ₂ (Nm)	kW ₁	HP ₁	RD	fs	P.A.M.
2800	21.40	131	369	5.5	7.5	0.92	2.19	28/250 - 24/200
	25.68	109	443	5.5	7.5	0.92	2.03	28/250 - 24/200
	33.16	84	572	5.5	7.5	0.92	1.54	28/250 - 24/200
	37.74	74	261	2.2	3.0	0.92	3.52	24/200 - 19/200
	40.44	69	698	5.5	7.5	0.92	1.26	28/250 - 24/200
	48.74	57	336	2.2	3.0	0.92	2.67	24/200 - 19/200
	52.70	53	661	4.0	5.5	0.92	1.09	28/250 - 24/200
	59.44	47	410	2.2	3	0.92	2.19	24/200 - 19/200
	72.91	38	343	1.5	2	0.92	2.68	14/160
	77.47	36	535	2.2	3	0.92	1.35	24/200 - 19/200
	88.91	31	418	1.5	2	0.92	2.19	14/160
	115.88	24	545	1.5	2	0.92	1.32	14/160

1400	21.40	65	900	6.7	9.1	0.92
	25.68	55	1000	6.2	8.4	0.92
	33.16	42	980	4.7	6.4	0.92
	37.74	37	1020	4.3	5.9	0.92
	40.44	35	980	3.9	5.3	0.92
	48.74	29	1000	3.3	4.4	0.92
	52.70	27	800	2.4	3.3	0.92
	59.44	24	1000	2.7	3.6	0.92
	72.91	19	1020	2.2	3.0	0.92
	77.47	18	800	1.6	2.2	0.92
	88.91	16	1020	1.8	2.5	0.92
	115.88	12	800	1.1	1.5	0.92

1400	21.40	65	537	4.0	5.5	0.92	1.68	28/250 - 24/200
	25.68	55	645	4.0	5.5	0.92	1.55	28/250 - 24/200
	33.16	42	832	4.0	5.5	0.92	1.18	28/250 - 24/200
	37.74	37	426	1.8	2.5	0.92	2.39	24/200 - 19/200
	40.44	35	1015	4.0	5.5	0.92	0.97	28/250 - 24/200
	48.74	29	551	1.8	2.5	0.92	1.82	24/200 - 19/200
	52.70	27	728	2.2	3.0	0.92	1.10	28/250 - 24/200
	59.44	24	671	1.8	2.5	0.92	1.49	24/200 - 19/200
	72.91	19	343	0.75	1.0	0.92	2.97	14/160
	77.47	18	729	1.50	2.0	0.92	1.10	24/200 - 19/200
	88.91	16	418	0.75	1.0	0.92	2.44	14/160
	115.88	12	545	0.75	1.0	0.92	1.47	14/160

900	21.40	42	990	4.7	6.4	0.92
	25.68	35	1100	4.4	6.0	0.92
	33.16	27	1078	3.3	4.5	0.92
	37.74	24	1122	3.0	4.1	0.92
	40.44	22	1078	2.7	3.7	0.92
	48.74	18	1100	2.3	3.1	0.92
	52.70	17	880	1.7	2.3	0.92
	59.44	15	1100	1.9	2.6	0.92
	72.91	12	1122	1.6	2.1	0.92
	77.47	12	880	1.2	1.6	0.92
	88.91	10	1122	1.3	1.8	0.92
	115.88	8	880	0.8	1.1	0.92

900	21.40	42	460	2.2	3.0	0.92	2.15	28/250 - 24/200
	25.68	35	552	2.2	3.0	0.92	1.99	28/250 - 24/200
	33.16	27	712	2.2	3.0	0.92	1.51	28/250 - 24/200
	37.74	24	405	1.1	1.5	0.92	2.77	24/200 - 19/200
	40.44	22	869	2.2	3	0.92	1.24	28/250 - 24/200
	48.74	18	523	1.1	1.5	0.92	2.10	24/200 - 19/200
	52.70	17	926	1.8	2.5	0.92	0.95	28/250 - 24/200
	59.44	15	638	1.1	1.5	0.92	1.72	24/200 - 19/200
	72.91	12	391	0.55	0.75	0.92	2.87	14/160
	77.47	12	832	1.1	1.5	0.92	1.06	24/200 - 19/200
	88.91	10	477	0.55	0.75	0.92	2.35	14/160
	115.88	8	622	0.55	0.75	0.92	1.41	14/160

DIMENSIONI D'INGOMBRO

OVERALL DIMENSIONS

ALLGEMEINE ABMESSUNGEN

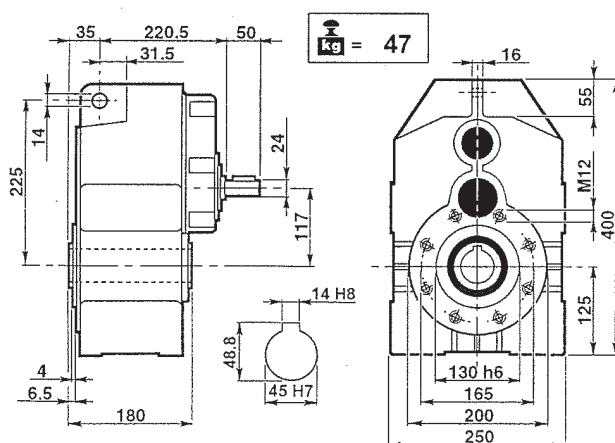

PD 100/3

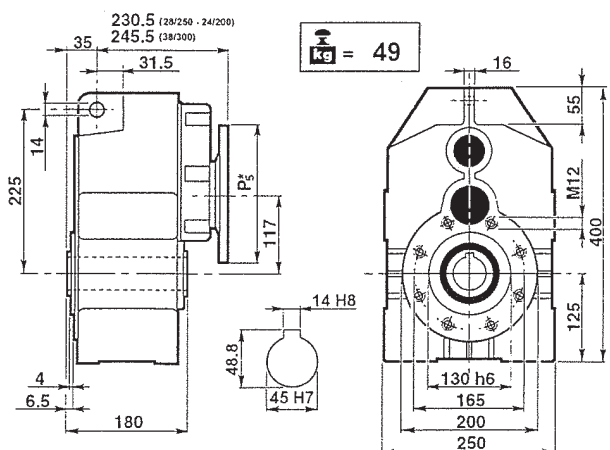

MPD 100/3

P₅* : Vedere i PAM per ogni singola versione
 P₅* : See PAM size for each single version
 P₅* : Siehe PAM Grösse für jede Ausführung

PD 125

PRESTAZIONI

PERFORMANCES

LEISTUNG

MPD 125

n ₁	i	n ₂	M ₂ (Nm)	kW ₁	HP ₁	RD
----------------	---	----------------	------------------------	-----------------	-----------------	----

2800	10.48	267	1440	42.0	57.1	0.96
	13.49	208	1440	32.6	44.3	0.96
	16.28	172	1440	27.0	36.7	0.96
	16.43	170	1305	24.3	33.0	0.96
	18.60	151	1620	26.6	36.2	0.96
	20.96	134	1530	22.3	30.3	0.96
	25.52	110	1485	17.8	24.2	0.96
	28.90	97	1305	13.8	18.8	0.96

1400	10.48	134	1600	23.3	31.7	0.96
	13.49	104	1600	18.1	24.6	0.96
	16.28	86	1600	15.0	20.4	0.96
	16.43	85	1450	13.5	18.3	0.96
	18.60	75	1800	14.8	20.1	0.96
	20.96	67	1700	12.4	16.8	0.96
	25.52	55	1650	9.9	13.4	0.96
	28.90	48	1450	7.7	10.4	0.96

900	10.48	86	1760	16.5	22.4	0.96
	13.49	67	1760	12.8	17.4	0.96
	16.28	55	1760	10.6	14.4	0.96
	16.43	55	1595	9.5	13.0	0.96
	18.60	48	1980	10.5	14.2	0.96
	20.96	43	1870	8.8	11.9	0.96
	25.52	35	1815	7.0	9.5	0.96
	28.90	31	1595	5.4	7.4	0.96

n ₁	i	n ₂	M ₂ (Nm)	kW ₁	HP ₁	RD	fs	P.A.M.
----------------	---	----------------	------------------------	-----------------	-----------------	----	----	--------

2800	10.48	267	635	18.5	25	0.96	2.27	42/350 - 38/300
	13.49	208	817	18.5	25	0.96	1.76	42/350 - 38/300
	16.28	172	986	18.5	25	0.96	1.46	42/350 - 38/300
	16.43	170	995	18.5	25	0.96	1.31	42/350 - 38/300
	18.60	151	1127	18.5	25	0.96	1.44	42/350 - 38/300
	20.96	134	1270	18.5	25	0.96	1.21	42/350 - 38/300
	25.52	110	1253	15	20	0.96	1.18	42/350 - 38/300
	28.90	97	1041	11	15	0.96	1.25	42/350 - 38/300

1400	10.48	134	1029	15	20	0.96	1.55	42/350 - 38/300
	13.49	104	1325	15	20	0.96	1.21	42/350 - 38/300
	16.28	86	1599	15	20	0.96	1.00	42/350 - 38/300
	16.43	85	1184	11	15	0.96	1.23	42/350 - 38/300
	18.60	75	1827	15	20	0.96	0.99	42/350 - 38/300
	20.96	67	1510	11	15	0.96	1.13	42/350 - 38/300
	25.52	55	1537	9.2	12.5	0.96	1.07	42/350 - 38/300
	28.90	48	1419	7.5	10	0.96	1.02	42/350 - 38/300

900	10.48	86	1174	11	15	0.96	1.50	42/350 - 38/300
	13.49	67	1512	11	15	0.96	1.16	42/350 - 38/300
	16.28	55	1824	11	15	0.96	0.96	42/350 - 38/300
	16.43	55	1255	7.5	10	0.96	1.27	42/350 - 38/300
	18.60	48	2084	11	15	0.96	0.95	42/350 - 38/300
	20.96	43	1601	7.5	10	0.96	1.17	42/350 - 38/300
	25.52	35	1430	5.5	7.5	0.96	1.27	42/350 - 38/300
	28.90	31	1619	5.5	7.5	0.96	0.99	42/350 - 38/300

DIMENSIONI D'INGOMBRO

OVERALL DIMENSIONS

ALLGEMEINE ABMESSUNGEN

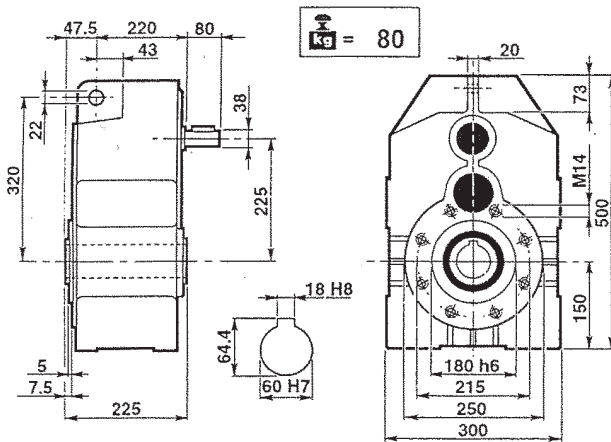

PD 125

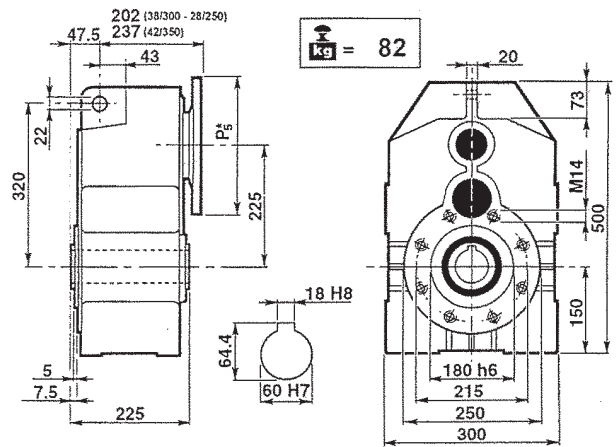

MPD 125

P₅* : Vedere i PAM per ogni singola versione
P₅* : See PAM size for each single version
P₅* : Siehe PAM Grösse für jede Ausführung

CARICHI RADIALI (N)

OVERHUNG LOADS (N)

RADIALE BELASTUNGEN (N)

ALBERO VELOCE / INPUT SHAFT / EINGANGSWELLE		
1400 min ⁻¹	PD 125	PD 125/3
	2100	1600

ALBERO LENTO / OUTPUT SHAFT / ABTRIEBSWELLE							
PD 125 - PD 125/3							
min ⁻¹	0°	30°	60°	90°	120°	150°	180°
20	18837	19474	21133	23681	26607	28896	29799
40	14245	14889	16415	18963	21896	24310	25211
60	12096	12604	14133	16678	19607	22022	23041
80	10567	11078	12604	15152	18081	20626	21515
100	9548	10059	11456	13993	16926	19439	20496
120	8782	9167	10693	13115	16170	18715	19733
140	8148	8505	9921	12168	15003	17364	18309
160	7637	7972	9299	11405	14063	16275	17161

Rotazione oraria
Clockwise
rotation
Uhrzeigersinn

Rotazione antioraria
Anticlockwise
rotation
Gegenuhrzeigersinn

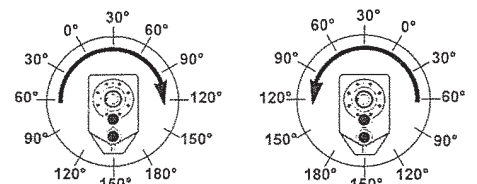

PD 125/3

PRESTAZIONI

PERFORMANCES

LEISTUNG

MPD 125/3

n ₁	i	n ₂	M ₂ (Nm)	kW ₁	HP ₁	RD
2800	26.47	106	1890	22.8	30.9	0.92
	30.32	92	1395	14.7	19.9	0.92
	34.08	82	1800	16.8	22.9	0.92
	38.46	73	1656	13.7	18.7	0.92
	41.49	67	1620	12.4	16.9	0.92
	47.25	59	1395	9.4	12.8	0.92
	53.11	53	1818	10.9	14.8	0.92
	59.60	47	1890	10.1	13.7	0.92
	64.66	43	1638	8.1	11.0	0.92
	73.22	38	1395	6.1	8.3	0.92
	93.42	30	1665	5.7	7.7	0.92
	105.79	26	1395	4.2	5.7	0.92

n ₁	i	n ₂	M ₂ (Nm)	kW ₁	HP ₁	RD	fs	P.A.M.
2800	26.47	106	914	11	15	0.92	2.07	38/300
	30.32	92	1047	11	15	0.92	1.33	38/300
	34.08	82	1176	11	15	0.92	1.53	38/300
	38.46	73	664	5.5	7.5	0.92	2.49	19/200
	41.49	67	1432	11	15	0.92	1.13	38/300
	47.25	59	815	5.5	7.5	0.92	1.71	28/250
	53.11	53	917	5.5	7.5	0.92	1.98	28/250
	59.60	47	1029	5.5	7.5	0.92	1.84	19/200
	64.66	43	1116	5.5	7.5	0.92	1.47	28/250
	73.22	38	1264	5.5	7.5	0.92	1.10	28/250
	93.42	30	1612	5.5	7.5	0.92	1.03	19/200
	105.79	26	1328	4.0	7.5	0.92	1.05	19/200

1400	26.47	53	2100	12.6	17.2	0.92
	30.32	46	1550	8.1	11.1	0.92
	34.08	41	2000	9.4	12.7	0.92
	38.46	36	1840	7.6	10.4	0.92
	41.49	34	1800	6.9	9.4	0.92
	47.25	30	1550	5.2	7.1	0.92
	53.11	26	2020	6.1	8.2	0.92
	59.60	23	2100	5.6	7.6	0.92
	64.66	22	1820	4.5	6.1	0.92
	73.22	19	1550	3.4	4.6	0.92
	93.42	15	1850	3.2	4.3	0.92
	105.79	13	1550	2.3	3.2	0.92

1400	26.47	53	1827	11	15	0.92	1.15	38/300
	30.32	46	1751	9.2	12.5	0.92	0.89	38/300
	34.08	41	1968	9.2	12.5	0.92	1.02	38/300
	38.46	36	965	4.0	5.5	0.92	1.91	19/200
	41.49	34	1432	5.5	7.48	0.92	1.26	38/300
	47.25	30	1188	4.0	5.5	0.92	1.31	28/250
	53.11	26	1333	4.0	5.5	0.92	1.52	28/250
	59.60	23	1496	4.0	5.5	0.92	1.40	19/200
	64.66	22	1623	4.0	5.5	0.92	1.12	28/250
	73.22	19	1379	3.0	4.0	0.92	1.12	28/250
	93.42	15	1759	3.0	4.0	0.92	1.05	19/200
	105.79	13	1461	2.2	3.0	0.92	1.06	19/200

900	26.47	34	2310	8.9	12.2	0.92
	30.32	30	1705	5.8	7.8	0.92
	34.08	26	2200	6.6	9.0	0.92
	38.46	23	2024	5.4	7.3	0.92
	41.49	22	1980	4.9	6.6	0.92
	47.25	19	1705	3.7	5.0	0.92
	53.11	17	2222	4.3	5.8	0.92
	59.60	15	2310	4.0	5.4	0.92
	64.66	14	2002	3.2	4.3	0.92
	73.22	12	1705	2.4	3.2	0.92
	93.42	10	2035	2.2	3.0	0.92
	105.79	9	1705	1.7	2.2	0.92

900	26.47	34	1421	5.5	7.5	0.92	1.63	38/300
	30.32	30	1628	5.5	7.5	0.92	1.05	38/300
	34.08	26	1830	5.5	7.5	0.92	1.20	38/300
	38.46	23	826	2.2	3.0	0.92	2.45	19/200
	41.49	22	1620	4.0	5.5	0.92	1.22	38/300
	47.25	19	1015	2.2	3	0.92	1.68	28/250
	53.11	17	1141	2.2	3	0.92	1.95	28/250
	59.60	15	1280	2.2	3	0.92	1.80	19/200
	64.66	14	1389	2.2	3	0.92	1.44	28/250
	73.22	12	1573	2.2	3	0.92	1.08	28/250
	93.42	10	2006	2.2	3	0.92	1.01	19/200
	105.79	9	1549	1.5	2	0.92	1.10	19/200

DIMENSIONI D'INGOMBRO

OVERALL DIMENSIONS

ALLGEMEINE ABMESSUNGEN

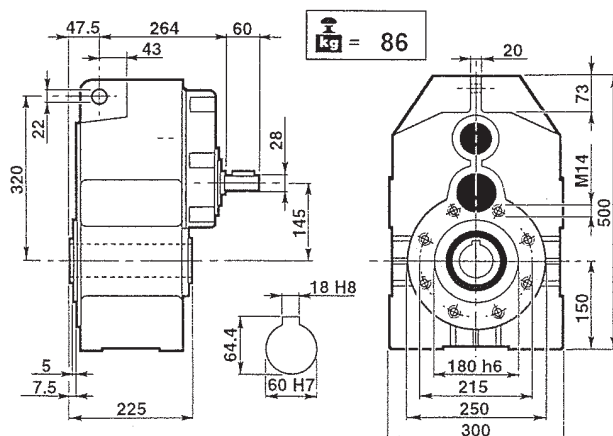

PD 125/3

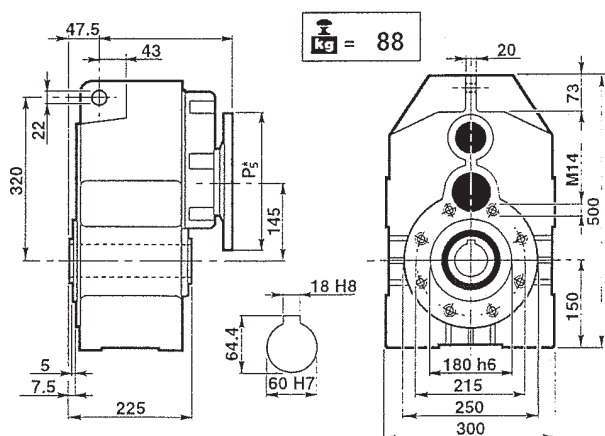

MPD 125/3

P₅* : Vedere i PAM per ogni singola versione
P₅* : See PAM size for each single version
P₅* : Siehe PAM Größe für jede Ausführung

PD 160

PRESTAZIONI

n ₁	i	n ₂	M ₂ (Nm)	kW ₁	HP ₁	RD
2800	9.87	284	2700	83.5	113.6	0.96
	12.74	220	2880	69.0	93.9	0.96
	15.54	180	2880	56.6	77.0	0.96
	16.27	172	3150	59.1	80.4	0.96
	19.87	141	2610	40.1	54.6	0.96
	21.01	133	3150	45.8	62.3	0.96
	25.62	109	2880	34.3	46.7	0.96
32.75	85	2700	25.2	34.2	0.96	
1400	9.87	142	3000	46.4	63.1	0.96
	12.74	110	3200	38.4	52.2	0.96
	15.54	90	3200	31.4	42.8	0.96
	16.27	86	3500	32.8	44.7	0.96
	19.87	70	2900	22.3	30.3	0.96
	21.01	67	3500	25.4	34.6	0.96
	25.62	55	3200	19.1	25.9	0.96
32.75	43	3000	14.0	19.0	0.96	
900	9.87	91	3300	32.8	44.6	0.96
	12.74	71	3520	27.1	36.9	0.96
	15.54	58	3520	22.2	30.2	0.96
	16.27	55	3850	23.2	31.6	0.96
	19.87	45	3190	15.8	21.4	0.96
	21.01	43	3850	18.0	24.5	0.96
	25.62	35	3520	13.5	18.3	0.96
32.75	27	3300	9.9	13.5	0.96	

PERFORMANCES

LEISTUNG

MPD 160

n ₁	i	n ₂	M ₂ (Nm)	kW ₁	HP ₁	RD	fs	P.A.M.
2800	9.87	284	808	25	34	0.96	3.34	48/350 - 42/350
	12.74	220	1043	25	34	0.96	2.76	48/350 - 42/350
	15.54	180	1272	25	34	0.96	2.26	48/350 - 42/350
	16.27	172	1332	25	34	0.96	2.37	48/350 - 42/350
	19.87	141	1627	25	34	0.96	1.60	48/350 - 42/350
	21.01	133	1720	25	34	0.96	1.83	48/350 - 42/350
	25.62	109	2097	25	34	0.96	1.37	48/350 - 42/350
32.75	85	2681	25	34	0.96	1.01	48/350 - 42/350	
1400	9.87	142	1422	22	30	0.96	2.11	48/350 - 42/350
	12.74	110	1835	22	30	0.96	1.74	48/350 - 42/350
	15.54	90	2239	22	30	0.96	1.43	48/350 - 42/350
	16.27	86	2344	22	30	0.96	1.49	48/350 - 42/350
	19.87	70	2863	22	30	0.96	1.01	48/350 - 42/350
	21.01	87	3027	22	30	0.96	1.16	48/350 - 42/350
	25.62	55	3104	18.5	25	0.96	1.03	48/350 - 42/350
32.75	43	3217	15	20	0.96	0.93	48/350 - 42/350	
900	9.87	91	1508	15	20	0.96	2.19	48/350 - 42/350
	12.74	71	1947	15	20	0.96	1.81	48/350 - 42/350
	15.54	58	2375	15	20	0.96	1.48	48/350 - 42/350
	16.27	55	2486	15	20	0.96	1.55	48/350 - 42/350
	19.87	45	3036	15	20	0.96	1.05	48/350 - 42/350
	21.01	43	3210	15	20	0.96	1.20	48/350 - 42/350
	25.62	35	2871	11	15	0.96	1.23	48/350 - 42/350
32.75	27	2502	7.5	10	0.96	1.32	48/350 - 42/350	

DIMENSIONI D'INGOMBRO

OVERALL DIMENSIONS

ALLGEMEINE ABMESSUNGEN

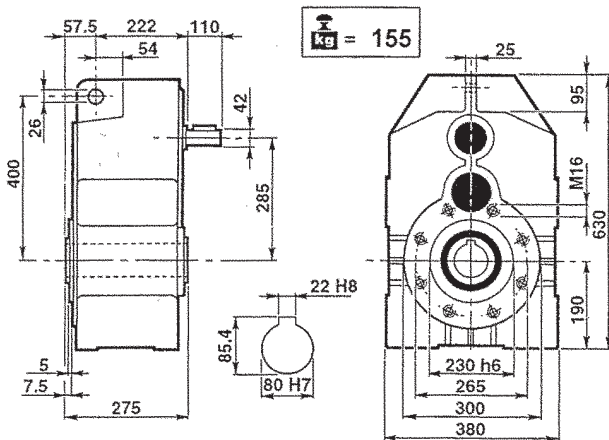

PD 160

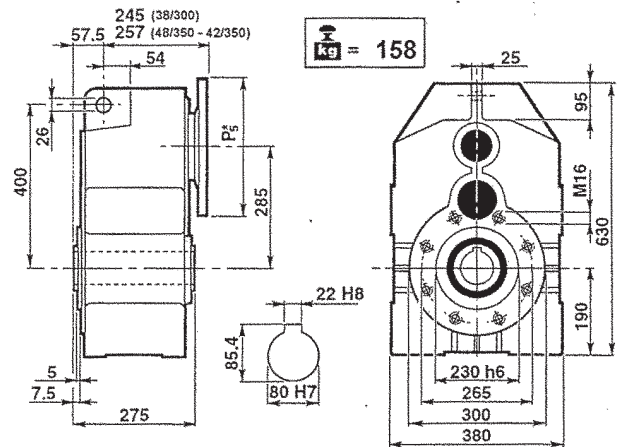

MPD 160

P₅*: Vedere i PAM per ogni singola versione
P₅*: See PAM size for each single version
P₅*: Siehe PAM Grösse für jede Ausführung

CARICHI RADIALI (N)

OVERHUNG LOADS (N)

RADIALE BELASTUNGEN (N)

ALBERO VELOCE / INPUT SHAFT / EINGANGSWELLE		
1400 min ⁻¹	PD 160	PD 160/3
	3200	2300

ALBERO LENTO / OUTPUT SHAFT / ABTRIEBSWELLE							
PD 160- PD 160/3							
min ⁻¹	0°	30°	60°	90°	120°	150°	180°
20	26910	27820	30190	33830	38010	41280	42570
40	20350	21270	23450	27090	31280	34729	36015
60	17280	18005	20190	23825	28010	31460	32915
80	15095	15825	18005	21645	25830	29465	30735
100	13640	14370	16365	19990	24180	27770	29280
120	12545	13095	15275	18735	23100	26735	28190
140	11640	12150	14173	17383	21434	24806	26156
160	10910	11388	13284	16293	20089	23251	24516

Rotazione oraria
Clockwise
rotation
Uhrzeigersinn

Rotazione antioraria
Anticlockwise
rotation
Gegenuhrzeigersinn

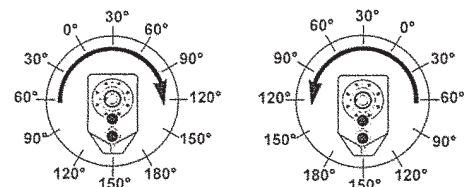

PD 160/3

PRESTAZIONI

PERFORMANCES

LEISTUNG

MPD 160/3

n ₁	i	n ₂	M ₂ (Nm)	kW ₁	HP ₁	RD
2800	34.24	82	3240	30.2	41.0	0.92
	39.47	71	2988	24.1	32.8	0.92
	41.78	67	3240	24.7	33.6	0.92
	50.46	55	2880	18.2	24.7	0.92
	53.36	52	3258	19.5	26.5	0.92
	58.57	48	3015	16.4	22.3	0.92
	65.07	43	3258	16.0	21.7	0.92
	71.52	39	2880	12.8	17.5	0.92
	75.63	37	3285	13.8	18.8	0.92
	83.19	34	2880	11.0	15.0	0.92
	92.23	30	3285	11.4	15.4	0.92
117.9	24	2880	7.8	10.6	0.92	

n ₁	i	n ₂	M ₂ (Nm)	kW ₁	HP ₁	RD	fs	P.A.M.
2800	34.24	82	2686	25	34	0.92	1.21	48/350 - 42/350
	39.47	71	1362	11	15	0.92	2.19	38/300
	41.78	67	3276	25	34	0.92	0.99	48/350 - 42/350
	50.46	55	1742	11	15	0.92	1.65	38/300
	53.36	52	1842	11	15	0.92	1.77	38/300
	58.57	48	1011	5.5	7.5	0.92	2.98	28/250
	65.07	43	2246	11	15	0.92	1.45	38/300
	71.52	39	1234	5.5	7.5	0.92	2.33	28/250
	75.63	37	1305	5.5	7.5	0.92	2.52	28/250
	83.19	34	2871	11	15	0.92	1.00	38/300
	92.23	30	1592	5.5	7.5	0.92	2.06	28/250
117.9	24	2035	5.5	7.5	0.92	1.42	28/250	

n ₁	i	n ₂	M ₂ (Nm)	kW ₁	HP ₁	RD
1400	34.24	41	3600	16.8	22.8	0.92
	39.47	35	3320	13.4	18.2	0.92
	41.78	34	3600	13.7	18.7	0.92
	50.46	28	3200	10.1	13.7	0.92
	53.36	26	3620	10.8	14.7	0.92
	58.57	24	3350	9.1	12.4	0.92
	65.07	22	3620	8.9	12.1	0.92
	71.52	20	3200	7.1	9.7	0.92
	75.63	19	3650	7.7	10.5	0.92
	83.19	17	3200	6.1	8.3	0.92
	92.23	15	3650	6.3	8.6	0.92
117.9	12	3200	4.3	5.9	0.92	

n ₁	i	n ₂	M ₂ (Nm)	kW ₁	HP ₁	RD	fs	P.A.M.
1400	34.24	41	3223	15	20	0.92	1.12	48/350 - 42/350
	39.47	35	2725	11	15	0.92	1.22	38/300
	41.78	34	3931	15	20	0.92	0.92	48/350 - 42/350
	50.46	28	2913	9.2	12.5	0.92	1.10	38/300
	53.36	26	3081	9.2	12.5	0.92	1.18	38/300
	58.57	24	1470	4.0	5.5	0.92	2.28	28/250
	65.07	22	3063	7.5	10	0.92	1.18	38/300
	71.52	20	1795	4.0	5.5	0.92	1.78	28/250
	75.63	19	1899	4.0	5.5	0.92	1.92	28/250
	83.19	17	2871	5.5	7.5	0.92	1.11	38/300
	92.23	15	2315	4.0	5.5	0.92	1.58	28/250
117.9	12	2960	4.0	5.5	0.92	1.08	28/250	

n ₁	i	n ₂	M ₂ (Nm)	kW ₁	HP ₁	RD
900	34.24	26	3960	11.8	16.1	0.92
	39.47	23	3652	9.5	12.9	0.92
	41.78	22	3960	9.7	13.2	0.92
	50.46	18	3520	7.1	9.7	0.92
	53.36	17	3982	7.6	10.4	0.92
	58.57	15	3685	6.4	8.8	0.92
	65.07	14	3982	6.3	8.5	0.92
	71.52	13	3520	5.0	6.9	0.92
	75.63	12	4015	5.4	7.4	0.92
	83.19	11	3520	4.3	5.9	0.92
	92.23	10	4015	4.5	6.1	0.92
117.9	8	3520	3.1	4.2	0.92	

n ₁	i	n ₂	M ₂ (Nm)	kW ₁	HP ₁	RD	fs	P.A.M.
900	34.24	26	3677	11	15	0.92	1.08	48/350 - 42/350
	39.47	23	2119	5.5	7.5	0.92	1.72	38/300
	41.78	22	3058	7.5	10	0.92	1.30	48/350 - 42/350
	50.46	18	2709	5.5	7.5	0.92	1.30	38/300
	53.36	17	2865	5.5	7.5	0.92	1.39	38/300
	58.57	15	1258	2.2	3.0	0.92	2.93	28/250
	65.07	14	3494	5.50	7.5	0.92	1.14	38/300
	71.52	13	1536	2.2	3.0	0.92	2.29	28/250
	75.63	12	1624	2.2	3.0	0.92	2.47	28/250
	83.19	11	3248	4.0	5.5	0.92	1.08	38/300
	92.23	10	1981	2.2	3.0	0.92	2.03	28/250
117.9	8	2532	2.2	3.0	0.92	1.39	28/250	

DIMENSIONI D'INGOMBRO

OVERALL DIMENSIONS

ALLGEMEINE ABMESSUNGEN

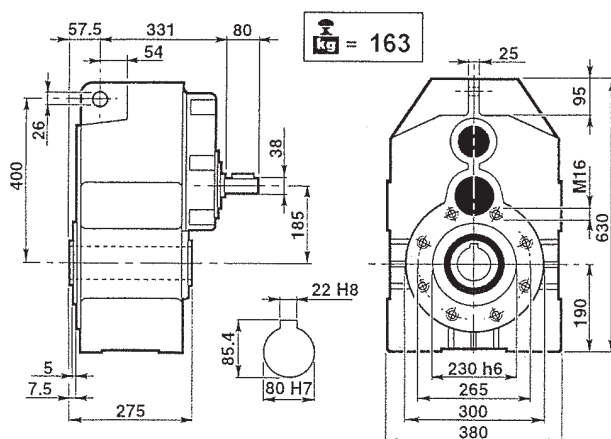

PD 160/3

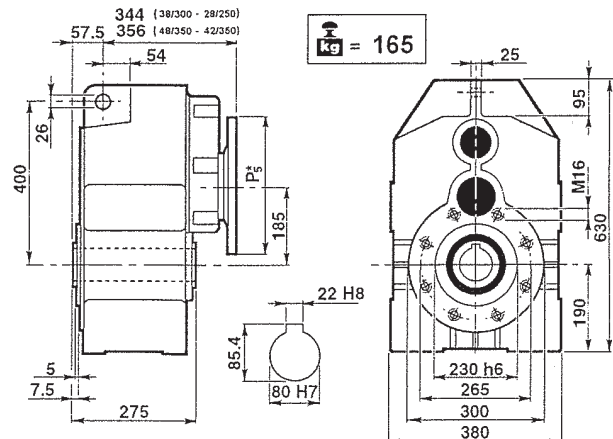

MPD 160/3

P₅* : Vedere i PAM per ogni singola versione
P₅* : See PAM size for each single version
P₅* : Siehe PAM Grösse für jede Ausführung

ACCESSORI
ACCESSORIES
 ZUBEHÖR

	Pag. Page <i>Seite</i>
FLANGIA IN USCITA OUTPUT FLANGES <i>ABTRIEBSFLANSCH</i>	54
ALBERI LENTI OUTPUT SHAFTS <i>STECKENWELLEN</i>	55
ALBERO VELOCE BISPORGENTE "OT" DOUBLE EXTENDED INPUT SHAFT "OT" <i>WELLENENDEN IM EINGANG (OT BAUREIHE)</i>	55
BRACCI DI REAZIONE TORQUE ARMS <i>DREHMOMENTSTÜTZEN</i>	56
BRACCI DI REAZIONE PER RIDUTTORI PENDOLARI TORQUE ARMS FOR SHAFT MOUNTED <i>DREHMOMENTSTÜTZEN FÜR FLACHGETRIEBE</i>	56
DISPOSITIVO ANTIRETRO BACKSTOP DEVICE <i>RUCKLAUFSPERRE</i>	57
ALBERO LENTO CAVO CON CALETTATORE OUTPUT HOLLOW SHAFT WITH COUPLER <i>ABTRIEBSHOHLWELLE MIT KUPPLER</i>	58

FLANGE IN USCITA

Tutti i riduttori delle serie OT, PL, PD possono essere equipaggiati, su richiesta, con flange in uscita di dimensioni unificate (flange B5). Si è optato per la forma quadrata sulle grandezze 63 - 80 - 100 e per la forma circolare sulle grandezze 125 e 160. Si assume come standard la posizione destra guardando il riduttore dal lato dell'entrata nella posizione di montaggio B3. Anche sulla grandezza OT 56 è di forma circolare.

OUTPUT FLANGES

All OT, PL and PD gearboxes can be equipped, upon request, with output B5 flanges. Square flanges have been provided on sizes 63 - 80 - 100 and round flanges are available on sizes 125 - 160. Standard position is on the right looking at the gearbox from input side in mounting position B3. Even on the size OT 56, it is round.

ABTRIEBSFLANSCH

Auf Anfrage können alle OT - PL - PD Getriebe mit einem genormten Abtriebsflansch (B5) geliefert werden. Für die Getriebe 63 - 80 und 100 sind rechteckige, für die Getriebe 125 und 160 sind runde Flansche vorgesehen. In der Standardausführung liegt der Flansch bei der Einbaulage B3 (Eingangswelle unten, Abtriebswelle oben) auf die Eingangswelle gesehen rechts. Auch auf der Größe OT 56 ist der Abtriebsflansch rund.

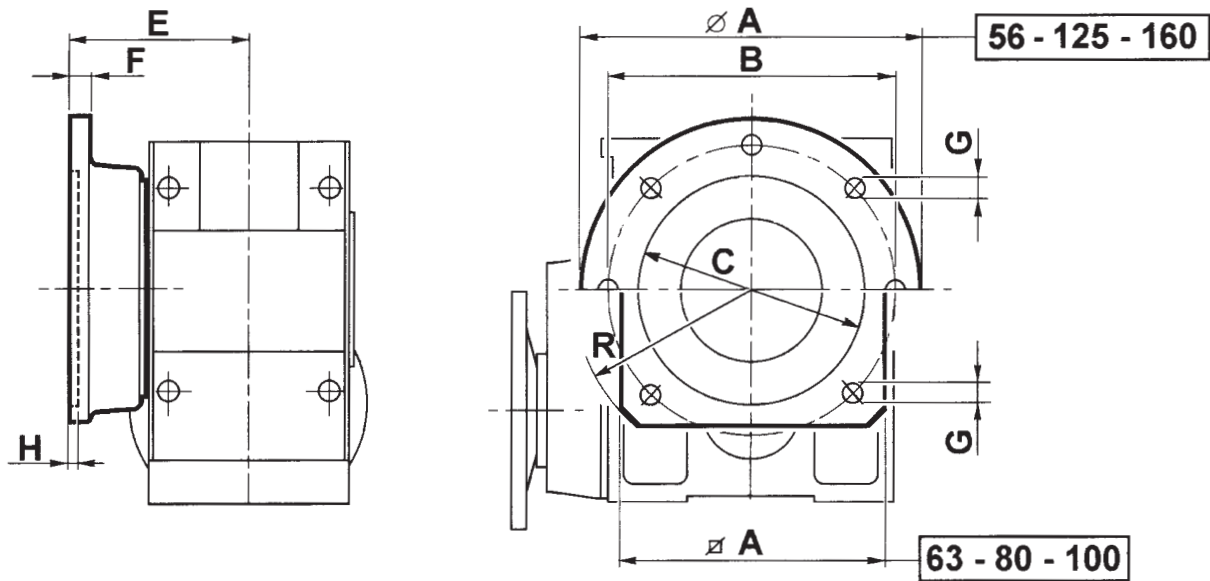

	○ A	□ A	B	C	E	F	G	H	R
56	160	-	130	110	80	11	4x11	5	-
63	-	150	165	130	113	12	4x11	5	100
80	-	190	215	180	132.5	14	4x14	6	125
100	-	240	265	230	150.5	16	4x16	5	150
125	350	-	300	250	174	18	8x16	6	-
160	450	-	400	350	195	20	8x18	7	-

ALBERI LENTI

Tutti i riduttori delle serie OT e PL possono essere equipaggiati, su richiesta, con alberi lenti semplici o con alberi lenti doppi.

Per l'albero lento semplice è realizzata la versione con spallamento, mentre sul lato opposto all'uscita della parte sporgente, il canotto è chiuso da apposita rondella.

L'albero lento doppio è invece realizzato, per semplicità costruttiva, con unico diametro, restando la funzione di spallamento affidata all'organo utilizzatore che sarà fissato alle estremità libere dell'albero.

OUTPUT SHAFTS

All OT and PL gearboxes can be equipped, on request, with single or double output shafts.

The single output shaft is accomplished in the version with shoulder, while on the opposite side the hollow shaft is closed by a suitable washer.

The double output shaft is, on the contrary, accomplished with a single diameter, for ease of manufacture. The function of shouldering is developed by the connection piece which will be placed on the free shaft ends.

STECKWELLEN

Alle OT und PL Getriebe können, auf Anfrage, mit einseitiger oder doppelseitiger Steckwelle ausgerüstet werden.

Die einseitige Ausführung ist mit einer Schulter ausgeführt, und die Hohlwelle ist bei einer Scheibe auf der gegenüberliegenden Seite geschlossen.

Die doppelseitige Steckwelle ist, für eine einfacheren Bau, mit einzeitigem Durchmesser ausgeführt, und die Schulterfunktion ist direkt von dem zusammenpassenden Maschinenteil entwickelt.

Albero lento semplice
Single output shaft
Einseitige Steckwelle

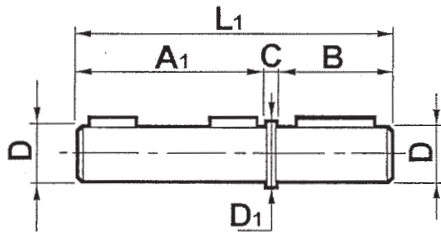

	D	B	D1	A1	C	L1
56	25	50	30	115	5	170
63	30	60	35	125	5	190
80	35	60	40	150	5	215
100	45	90	50	170	8	268
125	60	110	70	210	10	330
160	80	140	90	255	15	410

Albero lento doppio
Double output shaft
Doppelseitige Steckwelle

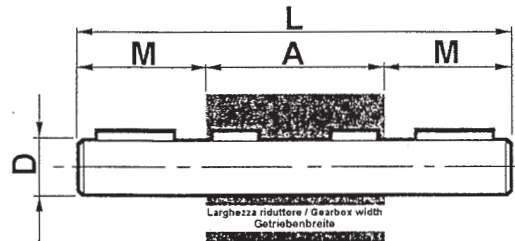

	D	A	L	M
56	25	120	220	50
63	30	135	255	60
80	35	160	280	60
100	45	180	360	90
125	60	225	445	110
160	80	275	555	140

ALBERO VELOCE BISPORGENTE OT

Su richiesta, gli OT possono essere forniti con albero veloce bisporgente.

La seconda sporgenza è realizzata con un secondo pignone conico posto sul lato opposto all'entrata che accoppia con la stessa corona conica.

Questa soluzione potrà essere adottata anche per i riduttori con precoppia.

In caso di esigenze particolari, sarà possibile provvedere la seconda sporgenza sull'albero intermedio parallelo all'asse di uscita.

DOUBLE EXTENDED INPUT SHAFT OT

Upon request, OT gearboxes can be supplied with double extended input shaft.

Second extension is achieved with a second bevel pinion on the opposite side of the input mating with the bevel gear.

Same solution can be adopted also for gearboxes with primary reduction.

When necessary, a second extension on the intermediate shaft parallel to the output axis could be provided.

WELLENENDEN IM EINGANG ("OT" BAUREIHE)

Auf Anfrage können die OT - Kegelstirnradgetriebe mit einem zweiten normalen Wellenende ausgeführt werden.

Das zweite Wellenende ist im Getriebeinnern als Kegelritzel ausgebildet und greift in den Kegelradteller ein.

Dies gilt ebenfalls für die Vorstufengetriebe.

In Sonderfällen kann das zweite Wellenende auch aus der mittleren Stufe, also parallel zu der Abtriebswelle, herausgeführt werden.

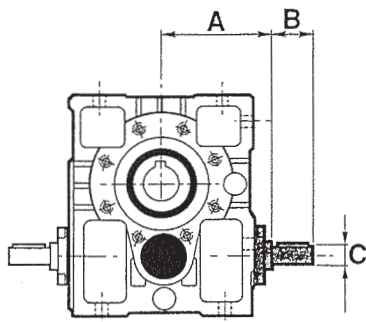

	A	B	C
OT 56	83	40	19
OT 63	95	40	19
OT 80	115	50	24
OT 100	140	60	28
OT 125	165	80	38
OT 160	210	110	42

BRACCI DI REAZIONE

I riduttori della serie OT possono essere anche equipaggiati, come accessorio, con braccio di reazione per montaggio pendolare.

I bracci di reazione della SITI consentono di poter essere applicati sia sulla superficie normale di appoggio del riduttore nel montaggio B3, sia sul lato superiore o sulla superficie laterale opposta al lato di entrata, in virtù della dimensioni di foratura esattamente uguali su tutte queste facce.

Possono inoltre essere posti o nella posizione mostrata sulla figura, o nella posizione simmetricamente speculare ad essa rispetto all'asse verticale di figura.

Essi sono stati dimensionati per poter resistere, con elevati margini di sicurezza, a tutti i massimi carichi che possono essere applicati sull'uscita, così come ai massimi pesi dei riduttori montati con motore.

TORQUE ARMS

Every gearbox of the OT line can be equipped with a torque arm, an optional item needed to mount the gearbox in a swinging position.

SITI torque arms can be applied on any side of OT gearboxes (upper, lower, etc.) thanks to the fact that all sides are identically drilled.

Moreover, torque arms can be mounted both according to the position shown in the sketch or the symmetrical one with respect to the vertical axis of figure.

All torque arms have been sized to bear heaviest loads on the output shaft as well as the biggest weights of all applicable motors.

DREHMOMENTSTUTZEN

Die OT - Getriebe können mit dazugehöriger Drehmomentstütze in Aufsteckausführung montiert werden.

Die Drehmomentstütze ist auch als Zubehör lieferbar.

Sie kann an jeder bearbeiteten Getriebeseite, die der Befestigung des Getriebes dient, montiert werden.

Die Drehmomentstützen können sowohl wie in der Abbildung dargestellt, als auch spiegelbildlich, angebracht werden.

Sie sind so konzipiert, daß sie mit hoher Sicherheit die maximale Belastung im Ausgang des Getriebes und das höchste Gewicht des Getriebes bzw. des Getriebemotors aushalten können.

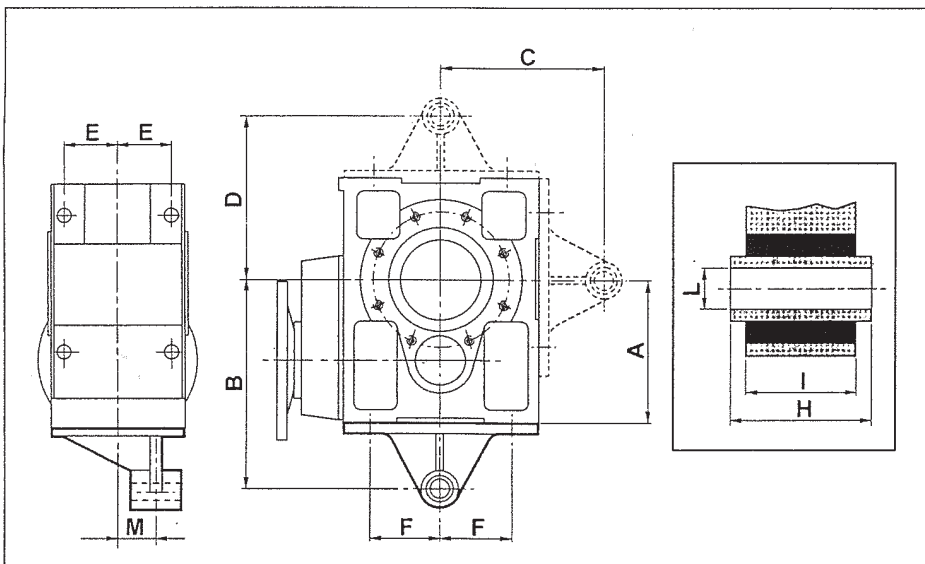

	63	80	100	125	160
A	120	155	180	220	280
B	168	219	257	308	415
C	128	164	202	238	325
D	128	164	202	238	325
E	46	55	65	80	100
F	50	67.5	85	100	125
H	60	60	80	100	100
I	52	52	70	90	90
L	15	18	22	25	30
M	31.5	44	45	55	80

BRACCI DI REAZIONE PER RIDUTTORI PENDOLARI

TORQUE ARMS FOR SHAFT MOUNTED

DREHMOMENTSTÜTZEN FÜR FLACHGETRIEBE

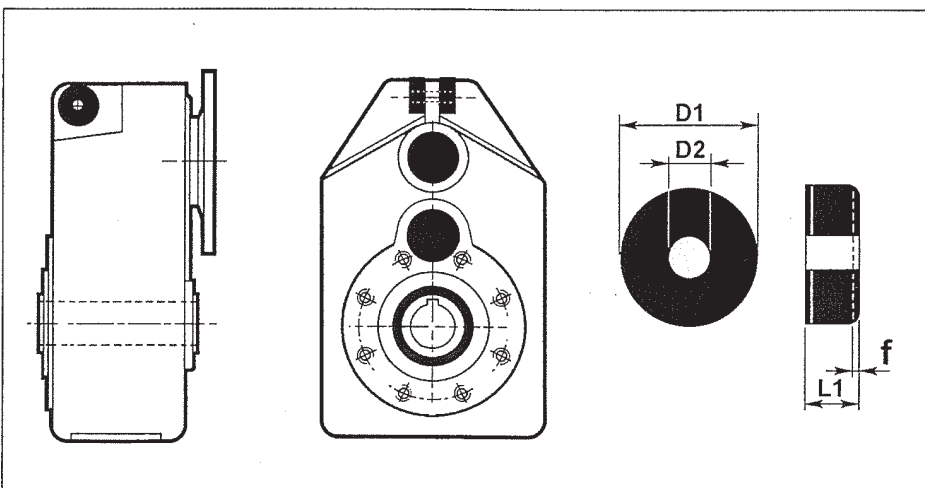

	63	80	100	125	160
D1	30	40	40	60	80
L1	15	20	20	30	40
D2	11	12.5	12.5	21	25
f _{min}	-	1.5	1.5	3	3.7
f _{max}	-	2.3	2.3	4	6

DISPOSITIVO ANTIRETRO

A richiesta, è possibile fornire i riduttori OT provvisti di dispositivo antiretro, per evitare il moto retrogrado, ovvero il fatto che il riduttore possa essere azionato attraverso l'albero lento dal carico resistente divenuto carico motore.

L'antiretro è provvisto per l'installazione sulla seconda sporgenza dell'albero veloce, a valle dei due cuscinetti conici, come appare dalla figura in sezione.

I cuscinetti antiretro sono stati ampiamente dimensionati in funzione della massima coppia permessa da ogni riduttore, e pertanto ne è consentito l'impiego con qualsiasi rapporto di riduzione, anche particolarmente veloce.

Dovrà essere sempre precisato in fase d'ordine per quale senso di rotazione deve essere consentita la rotazione libera.

BACKSTOP DEVICE

On request it is possible to have backstop mounted on the OT line. Purpose of the backstop is to prevent the reversible motion, that is the fact that the gearbox might be operated through the output shaft by the resisting load so becoming driving load.

The backstop device is located on the input shaft downstream the two taper roller bearings as we can see from the sketch enclosed.

The irreversible bearing have been largely oversized according to the maximum torque allowed by each gearbox so that backstop devices are suitable for any reduction ratio.

The direction of free rotation must be specified when the order is placed.

RÜCKLAUFSPERRE

Die Rücklaufsperrre ist eine Einrichtung im Getriebe, um die Anlage nach dem Abschalten des Motors am Rückwärtslauf zu hindern.

Wie in dem Ausschnitt ersichtlich, ist die Anbringung der Rücklaufsperrre an der gegenüberliegenden Seite der Eingangswelle vorgesehen.

Die Rücklaufsperrre ist ausreichend dimensioniert und kann an jedem Getriebe sowohl mit hohen als auch mit niedrigen Untersetzungen angebaue werden.

Bei Bestellung muß der Drehsinn stets angegeben werden.

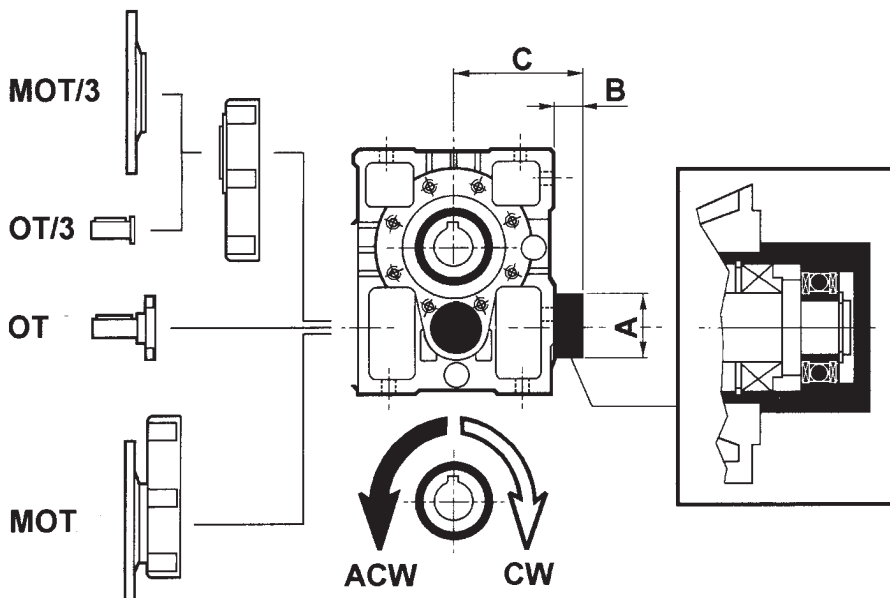

	A	B	C
63	62	39.6	119.6
80	72	41	141
100	78	42	167
125	74.9	49.6	199.6
160	74.9	54.6	244.6

Anche sui riduttori PL e PD il dispositivo antiretro può essere applicato sulla seconda sporgenza dell'albero veloce.

Even on PL and PD, the backstop device might be fitted on the second end of the input shaft.

Auch auf PL und PD, kann die Rücklaufsperrre auf der gegenüberliegenden Seite der Eingangswelle vorgesehen sein.

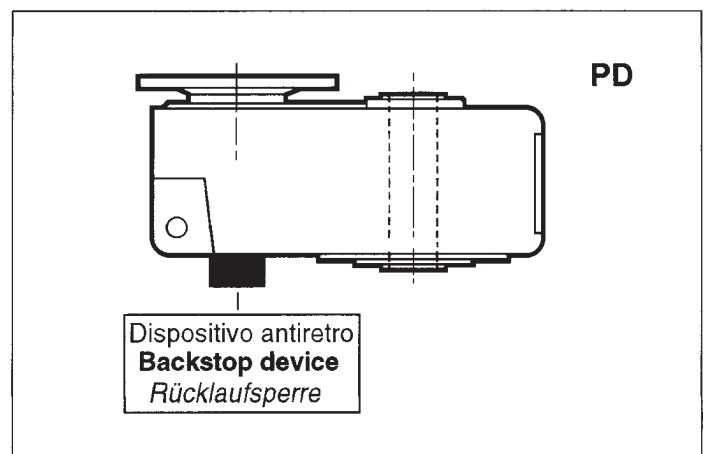
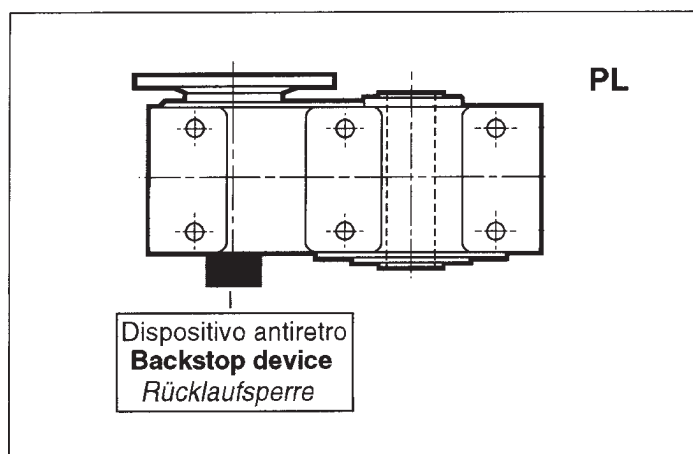

ALBERO LENTO CAVO CON CALETTATORE

OUTPUT HOLLOW SHAFT WITH COUPLER

ABTRIEBSHOHLWELLE MIT KUPPLER

Dimensionamento e tolleranze alberi lenti cavi con calettatore su riduttori serie OT/2 e OT3.

Dimensions and tolerances of input hollow shafts with coupler for gearboxes of the OT/2 and OT3 series.

Bemessung und Toleranzen der Abtriebshohlwellen mit Kuppler an Untersetzungsgetrieben der Serie OT/2 und OT3.

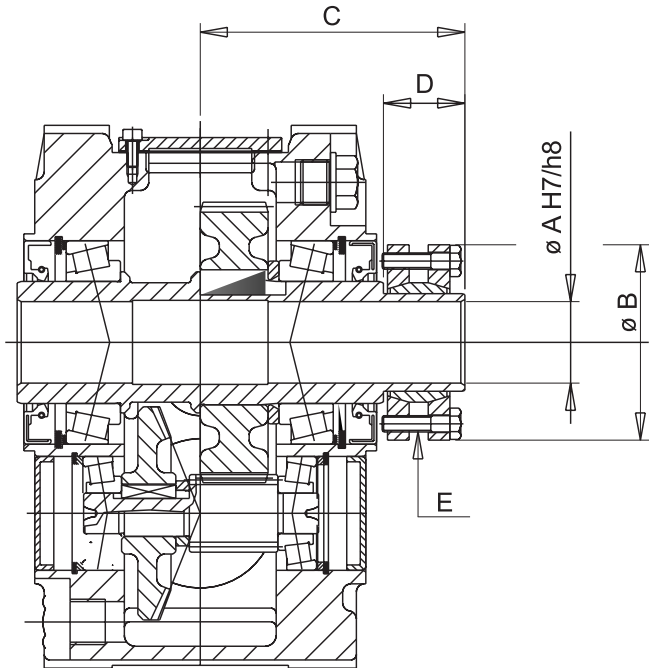

	$\varnothing A$	$\varnothing B$	C	D	E	Ts Nm
OT 56	25	60	88	28	M 5	4
OT 63	30	72	98	30	M 6	12
OT 80	35	80	112	32	M 6	12
OT 100	45	100	127	37	M 6	12
OT 125	60	115	151	38	M 6	12
OT 160	80	170	188	53	M 8	30

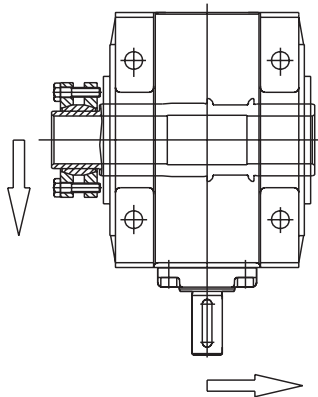

STANDARD - **STANDARD** - STANDARD

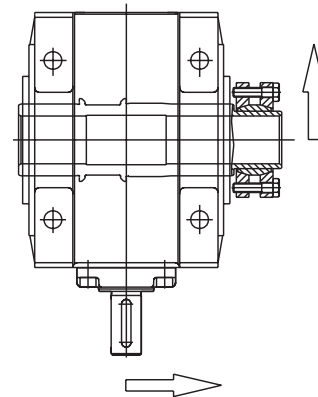

A RICHIESTA - **ON REQUEST** - AUF WUNSCH

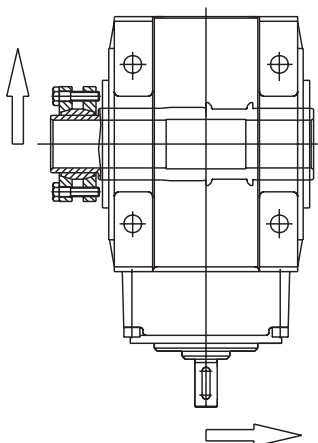

STANDARD - **STANDARD** - STANDARD

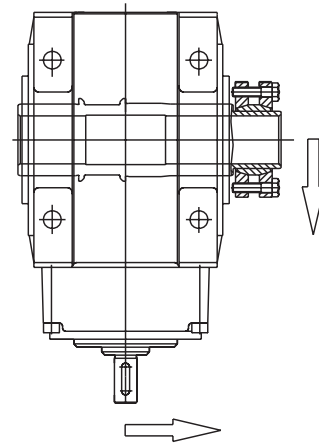

A RICHIESTA - **ON REQUEST** - AUF WUNSCH

Potenze		Power	Leistungen	
1 Ft · Lb/min	= 0.0226 watt	1 watt	= 44.25 Ft · Lb/min.	
1 Ft · Lb/sec.	= 0.001818 HP (PS)	1 HP (PS)	= 550 Ft · Lb/sec.	
1 Ft · Lb/min.	= 0.030 · 10 ⁻⁴ HP (PS)	1 HP (PS)	= 33000 Ft · Lb/min.	

Coppia		Torque	Drehmoment	
1 Ft · Lb	= 0.1383 Kgm	1 Kgm	= 7.233 Lb · Ft	

Momento d'inerzia		Inertia moment	Trägheitsmoment	
(WR ²) 1 Lb · Ft ²	= 0.0422 Kgm ²	(J) 1 Kgm ²	= 23.69 Lb · Ft ²	

Lunghezza		Length	Länge	
1 mil	= 0.0254 mm	1 mm	= 39.37 mil	
1 inch	= 2.54 cm	1 cm	= 0.3937 inch (In.)	
1 foot	= 30.48 cm = 12 inches	1 cm	= 0.032 foot (Ft)	
1 yard	= 91.439 cm = 3 feet	1 cm	= 0.01094 yard (Yd)	
1 mile	= 1.609 Km = 1760 yards	1 Km	= 0.6214 mile	

Pesi		Loads	Gewichte	
1 grain	= 0.0648 g	1 gramm	= 15.5 grain	
1 ounce	= 28.349 g	1 gramm	= 0.03527 ounce (Oz.)	
1 pound	= 453.592 g	1 gramm	= 0.0022 pound (Lb)	
1 pound	= 0.4536 Kg	1 Kilogramm	= 2.2 pound (Lb)	
1 Cwt	= 50.802 Kg	1 Kilogramm	= 0.01968 Cwt.	
1 ton (ingl)	= 1016.048 Kg	1 Kilogramm	= 0.00098 ton. (ingl.)	
1 ton (U.S.A.)	= 907.185 Kg	1 Kilogramm	= 0.00111 ton. (U.S.A.)	
1 pound	= 0.00893 Cwt.	1 hundredweight (Cwt.)	= 112 pound	
1 ounce/gallon	= 6.235 g/litro	1 gramm/liter	= 0.1604 ounce/gallon	

Superfici		Surface	Flächen	
1 circular mil	= 5.067 x 10 ⁴ mm ²	1 mm ²	= 1974 circular mil	
1 square inch	= 6.452 cm ²	1 cm ²	= 0.1550 square inch	
1 square foot	= 929.03 cm ²	1 cm ²	= 0.00107 square foot	
1 square yard	= 0.8361 m ²	1 m ²	= 1.195 square yard	

Volumi		Volume	Volumen	
1 cubic inch	= 16.387 cm ³	1 cm ²	= 0.06102 cubic inch	
1 cubic foot	= 28316.084 cm ³	1 cm ³	= 0.000035 cubic foot	
1 cubic yard	= 0.76455 m ³	1 m ³	= 1.307 cubic yard	
1 cubic inch	= 0.01630 litro	1 liter	= 61.02 cubic inch	
1 gallon (imperial)	= 4.541 litro	1 liter	= 0.2202 gallon (imperial)	
1 pint	= 0.568	1 liter	= 1.77 pint	
1 gallon (imperial)	= 1.997 gallon (U.S.A.)	1 gallon (U.S.A.)	= 0.8336 gallon (imperial)	

CONDIZIONI GENERALI DI VENDITA

1) GARANZIA - La ns. garanzia ha la durata di anni uno dalla data di fatturazione del prodotto. Essa è limitata esclusivamente alla riparazione o alla sostituzione gratuita dei pezzi da noi riconosciuti come difettosi ed il reclamo non potrà mai dar luogo all'annullamento od alla riduzione delle ordinazioni da parte del committente e tanto meno alla corresponsione di indennizzi di sorta da parte ns. Il materiale da riparare in garanzia o comunque soggetto ad anomalie, sarà da noi ritirato solo se ci perverrà in porto franco e sarà reso al cliente in porto assegnato. La ns. garanzia decade se i pezzi resi come difettosi sono stati comunque manomessi o riparati. **Per manomissione si intende anche l'applicazione del motore fuori dall' ambito e dalla sede della ns. Società.** La ns. garanzia non copre danni o difetti dovuti ad agenti esterni, deficienza di manutenzione, sovraccarico, lubrificante inadatto, scelta inesatta del tipo, errore di montaggio e danni derivati in seguito a trasporto da parte del committente o trasportatore designato, essendo la spedizione sempre a spese e rischio del committente.

2) TRASPORTO - Ad ogni effetto, anche di legge, la merce si ritiene accettata dal cliente (e consegnata) all'uscita dalla ns. sede o magazzini. Il trasporto della merce si intende sempre per conto, rischio e pericolo dell'acquirente anche se la merce è venduta franco destino e se il trasporto viene effettuato con mezzi della ditta venditrice e condotti da persona incaricata dalla medesima.

3) PREZZI - La ns. Società si riserva di modificare in qualsiasi momento le proprie quotazioni (anche se confermate) se ciò si rendesse necessario in conseguenza a mutevoli condizioni di mercato o di produzione. Il listino prezzi si riferisce a merce franco ns. stabilimento, escluso imballo ed ogni eventuale altra spesa.

4) RECLAMI - E' convenuto espressamente che eventuali reclami o contestazioni da farsi, a pena di nullità, sempre in forma scritta ed entro i termini di legge non danno comunque diritto all'acquirente di sospendere o ritardare i pagamenti. **Non si accettano addebiti per risarcimento di danni a cose e persone o ritardi di consegna.** Se entro 8 gg. dal ricevimento della ns. conferma d'ordine non ci perverrà alcuna contestazione, la stessa si intenderà accettata in tutte le sue parti.

5) INTERESSI - Resta espressamente convenuto che gli interessi verranno fissati ed accettati, in ogni sede di ritardato pagamento, secondo le condizioni medie di tasso applicato dagli Istituti Bancari alla Società venditrice in quel momento.

6) RISERVA DI PROPRIETA' - La merce viene venduta con riserva di proprietà finché non sarà effettuato il pagamento dell'intero prezzo, di eventuali interessi e accessori. Il rilascio di cambiali ed eventuali loro rinnovi, anche parziali, non potranno considerarsi quale novazione né quale pagamento definitivo del prezzo, se non a buon fine delle stesse, né potranno comunque pregiudicare la riserva di proprietà.

7) FORO COMPETENTE - Si accetta espressamente che qualsiasi controversia, comunque nascente o discendente dalla vendita deve essere rimessa, anche in via derogativa, al giudizio dell' Autorità Giudiziaria di Bologna, quale unico Foro competente; ma la ditta venditrice potrà anche adire, a sua scelta, l' autorità giudiziaria del luogo, della residenza o domicilio dell'acquirente ovvero del luogo ove si trova l'oggetto della fornitura.

8) RESI - NON SI ACCETTANO RESTITUZIONI DI MATERIALI se non precedentemente autorizzato per iscritto dalla ns. Società.

9) LISTINO - Il listino attualmente in vigore annulla e sostituisce tutti i precedenti.

TERMS AND CONDITIONS OF SALE

1) GUARANTEE - *Our guarantee expires after one year from invoice date of the product. It only covers the replacement or repair free of charge of the defective units or parts provided that we admit that said faults or defects are to be ascribed to manufacturing processes. The customer does not have to feel entitled to cancel or reduce the outstanding orders because of defective material previously supplied. We will not be responsible for the payment of any charges related to goods to be replaced or repaired under guarantee. Returns of material will only be accepted if both back and forth transport charges will be covered by the customer. Our guarantee becomes completely null and void if units result altered or repaired. **For alteration it is included also the application of the motor out of the ambit and circle of our Society.** Our guarantee does not cover defects or faults which would be attributed to external factors, insufficient maintenance, overload, inadequate lubrication, improper selection, mounting errors or shipping damages being shipment risks and expenses on behalf of the customer.*

2) SHIPMENT - *Material is considered accepted by the customer once it leaves our warehouse. Shipment of goods is considered at buyer's risk even if shipment is effected free domicile of customer or through shipper's means of transports or forwarding agents appointed by the shipper.*

3) PRICES - *Our Company reserve the right to modify their own quotations (although confirmed) if it is necessary because of the unconstant conditions of market and production. The price list refers to ex-works prices. Not including packing and any other additional costs.*

4) COMPLAINTS - *Complaints for defective material must be effected in writing and within the legal terms or they will be considered null. In case of complaints the buyer is not anyhow entitled to stop or delay payments. **Debit notes for refunds of damages to objects or persons as well as deliveries are not accepted.** Any claims should be notified within 8 days from receipt of our order confirmation, otherwise it will be considered as accepted in all its parts.*

5) INTERESTS - *It is understood that interests have to be agreed and accepted in occasion of late payments, according to the current average terms, applied by the Shipper's banks.*

6) CONDITIONAL SALE - *We reserve the right of property on goods sold until the whole payment has been effected together with the settlement of eventual interests and accessories. The grant of a bill or its eventual renewal cannot be considered as a definite payment of the price and will be subjected to collection.*

7) PLACE OF JURISDICTION - *All disputes which may arise in relation to the sale shall be governed by the Italian Law and the Law Court of Bologna shall have the sole jurisdiction. The supplier reserve the right to choose, as place of jurisdiction, the purchaser's place of residence being the final destination of goods supplied.*

8) NO RETURNS OF MATERIAL WILL BE ACCEPTED *unless previously authorised in writing from our Society.*

9) PRICE LIST - *This current price list cancels and replaces all the previous ones.*



SITI SPA

SOCIETÀ ITALIANA TRASMISSIONI INDUSTRIALI



RIDUTTORI

MOTORIDUTTORI

VARIATORI CONTINUI

MOTORI ELETTRICI C.A./C.C.

GIUNTI ELASTICI

GEARBOXES

GEARED MOTORS

SPEED VARIATORS

A.C./D.C. ELECTRIC MOTORS

FLEXIBLE COUPLINGS

SEDE e STABILIMENTO

HEADQUARTER

Via G. Di Vittorio, 4

40050 Monteveglio - BO - Italy

Tel. +39/051/6714811

Fax. +39/051/6714858

E-mail: info@sitiriduttori.it

commitalia@sitiriduttori.it

export@sitiriduttori.it

WebSite: www.sitiriduttori.it